

HAUS OF TENET

Positioned at the intersection of commerce and culture, Haus of Tenet introduces a new typology of office space in Dubai, one that goes beyond functionality to become a statement of legacy, influence and intent.



BUSINESS BAY

An address of access, influence and permanence.



A FIRST-OF-ITS-KIND, ART-LED OFFICE DESTINATION

Purpose-led architectural expression, where art informs form and design is driven by intent and every line, material and spatial decision is thoughtfully composed.





POSITIONED WITH INTENTION

At the intersection of connectivity, culture and commerce; complemented by intimate garden pockets that introduce calm and greenery into the urban fabric.

THE LOCATION AXIS

Haus of Tenet stands within Business Bay - Dubai's established district of enterprise and design. A location defined by access, prestige and permanence.



GUIDED BY LIGHT

Guided by the path of the sun, the building welcomes natural light throughout the day, creating spaces defined by balance, comfort and ease.



Summer Solistice
Sunrise

Winter Solistice
Sunset

THE URBAN CONTEXT

Positioned within a network of established landmarks and cultural destinations, the setting lends presence, prestige and long-term significance.

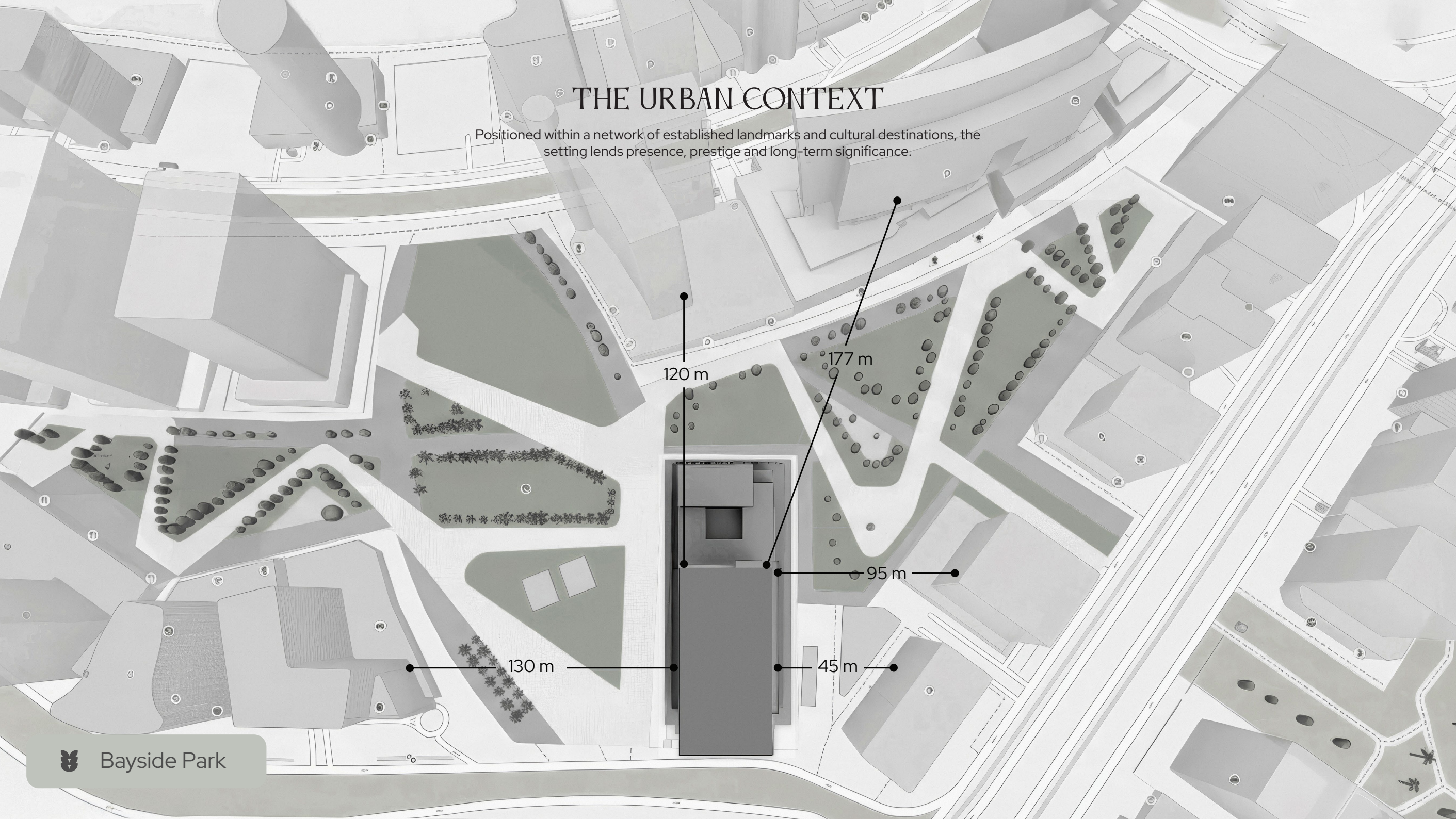

Bayside Park

DAY VIEW

BAY SIDE PARK / CANAL

BAY SIDE PARK / DOWNTOWN



CITY SKYLINE

NIGHT VIEW

BAY SIDE PARK / CANAL



BAY SIDE PARK / DOWNTOWN



W

E



S

CITY SKYLINE

A CHOSEN DESTINATION





THE OFFICE COLLECTION

A movement through shadows, designed for those who embody rare presence.

CANVAS OF POSSIBILITIES

Shell & Core offices designed for flexibility and light, featuring full-height windows with expansive city views, offering a blank canvas to shape your ideal work environment.



A modern conference room with a large, dark wood conference table and several orange upholstered chairs. The room features floor-to-ceiling windows that offer a panoramic view of a city skyline at dusk. The sky is a mix of orange and blue, and the city lights are visible. A person is standing in the background, looking out the window. The text "FOR THE FEW" is centered on the table.







FOR THE FEW

BUILDING CONFIGURATION

THE OFFICE COLLECTION

Delivered in shell & core, every workspace is crafted for focus, clarity and presence.

LEGEND

-  The Den
-  Classic Offices
-  Terrace Offices
-  Garden Offices
-  Amenities
-  Parking
-  Exclusive Lobby

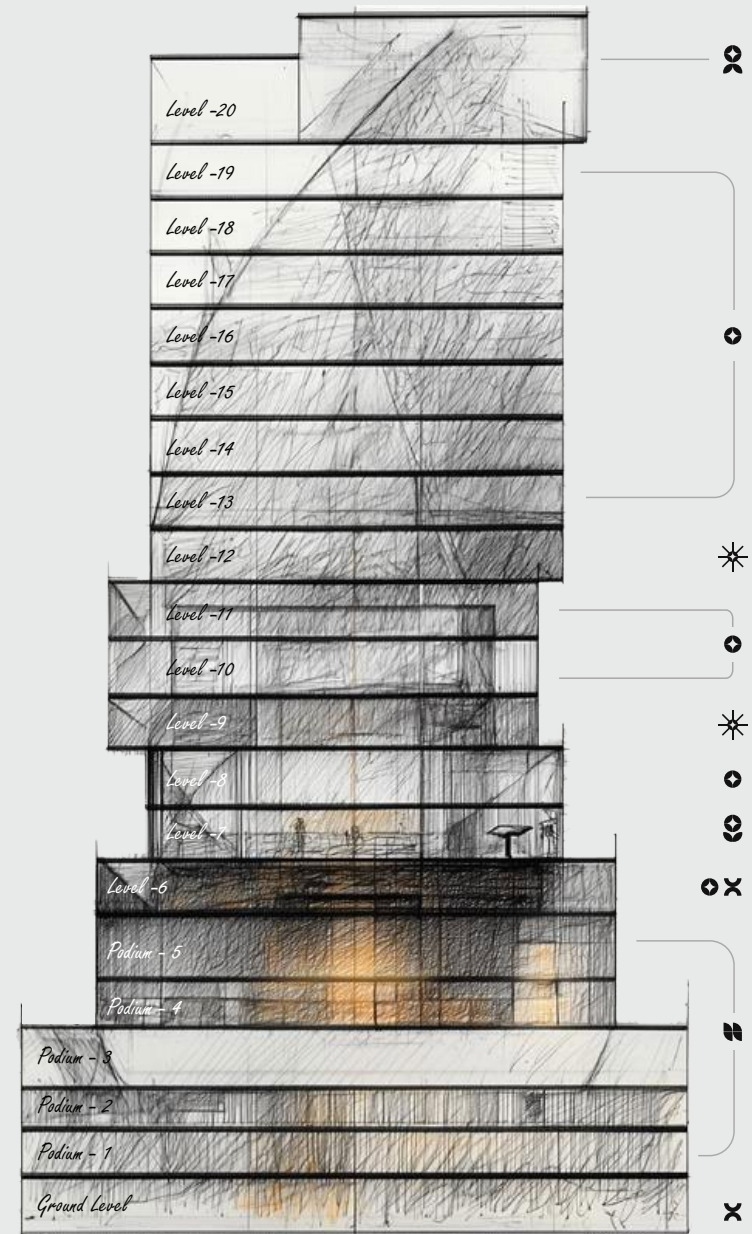

CLUSTER PHILOSOPHY

A Smarter Way to Work

The building introduces a refined cluster concept, designed for businesses that value flexibility, privacy and long-term growth.

Offices are thoughtfully arranged into distinct clusters, each accessed through a shared private lobby. This creates a calm, semi-private arrival experience while allowing multiple offices to operate seamlessly as one integrated workplace.

Each office remains independently owned, yet clusters can be combined to form larger, more fluid environments that evolve with the needs of their occupants.

This approach offers a rare balance between individuality and scale, enabling businesses to start small, expand naturally and remain rooted in one address.

An intelligent system of space, designed to adapt over time.

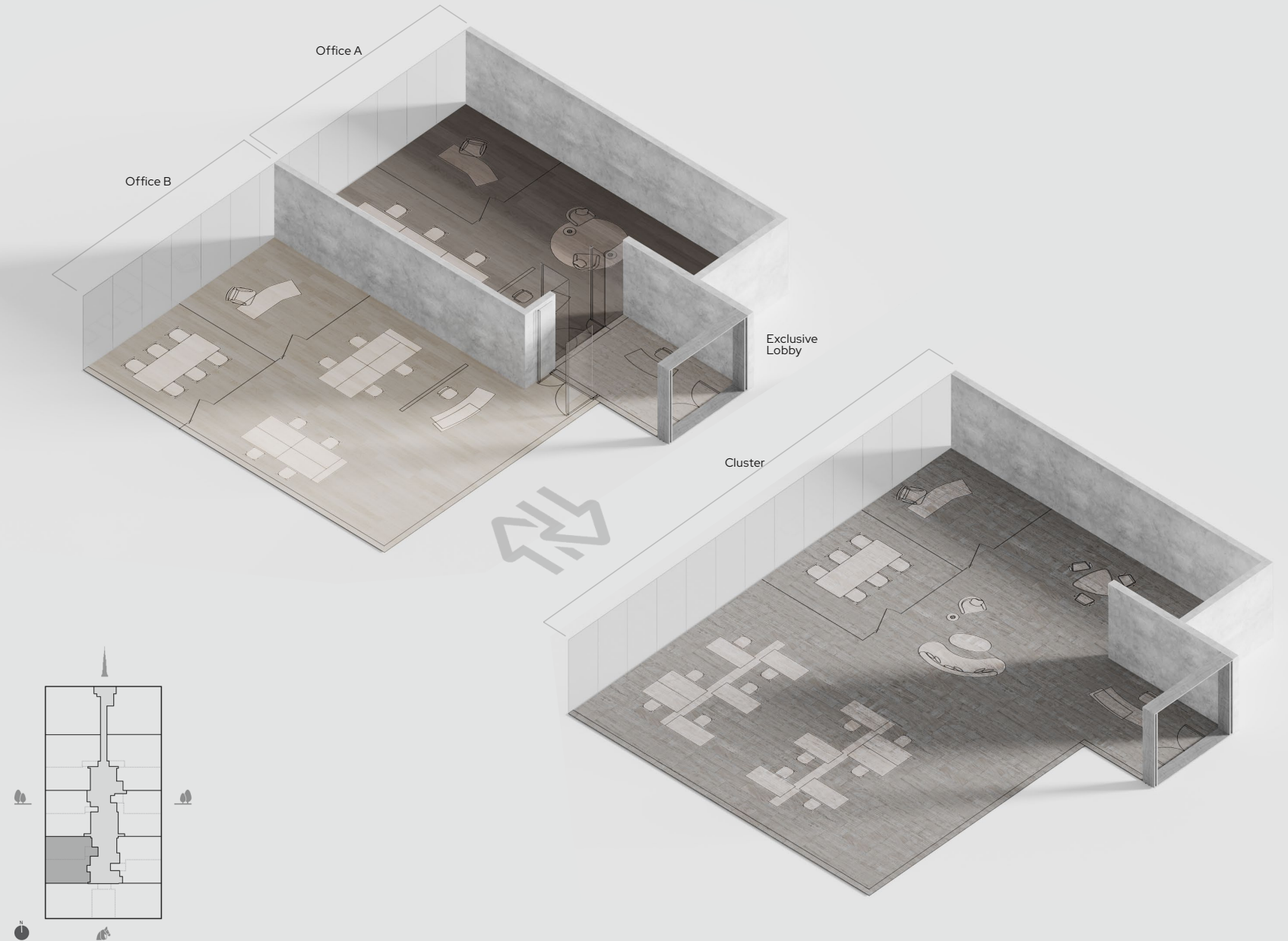

FLOOR PLANS

FLOOR 6

Classic Offices & Amenities

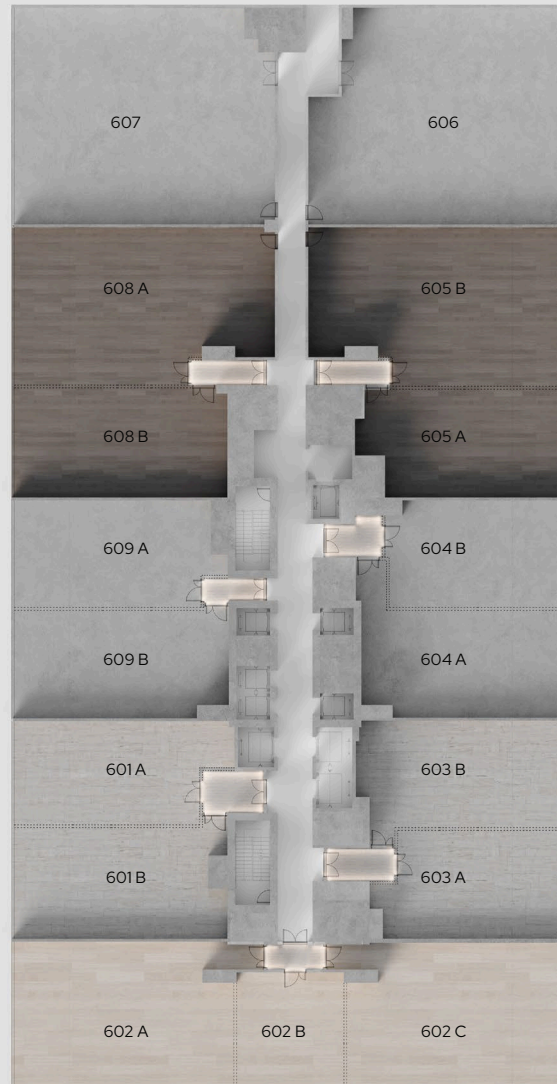
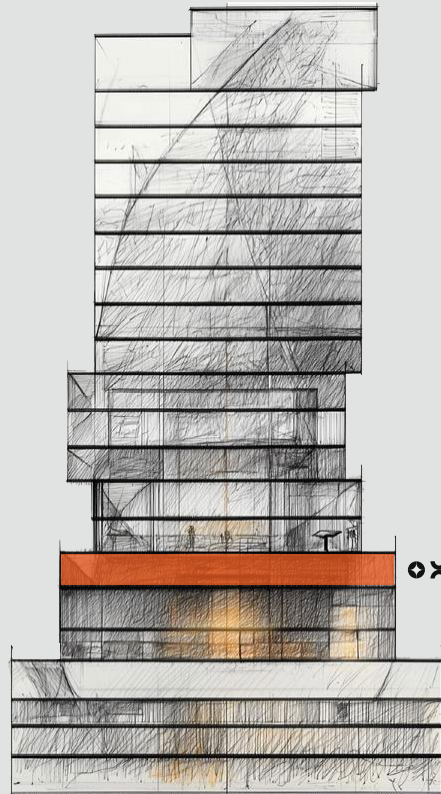

	INDOOR	PARKING	OCCUPANCY
CLUSTER 601	2822 FT ²	4	25
601A	1268 FT ²	2	12
601B	1384 FT ²	2	13
EXCLUSIVE LOBBY	170 FT ²		
CLUSTER 602	5351 FT ²	10	51
602A	2194 FT ²	4	21
602B	885 FT ²	2	9
602C	2184 FT ²	4	21
EXCLUSIVE LOBBY	88 FT ²		
CLUSTER 603	2638 FT ²	4	24
603A	1154 FT ²	2	11
603B	1339 FT ²	2	13
EXCLUSIVE LOBBY	145 FT ²		
CLUSTER 604	2648 FT ²	4	24
604A	1391 FT ²	2	11
604B	1111 FT ²	2	13
EXCLUSIVE LOBBY	146 FT ²		
CLUSTER 605	3610 FT ²	6	34
605A	1274 FT ²	2	12
605B	2217 FT ²	4	22
EXCLUSIVE LOBBY	119 FT ²		
606	3039 FT ²	6	30
607	3190 FT ²	6	31
CLUSTER 608	3718 FT ²	6	35
608A	2235 FT ²	4	22
608B	1361 FT ²	2	13
EXCLUSIVE LOBBY	122 FT ²		
CLUSTER 609	2716 FT ²	4	25
609A	1247 FT ²	2	12
609B	1360 FT ²	2	13
EXCLUSIVE LOBBY	109 FT ²		



FLOOR 7

Garden Offices

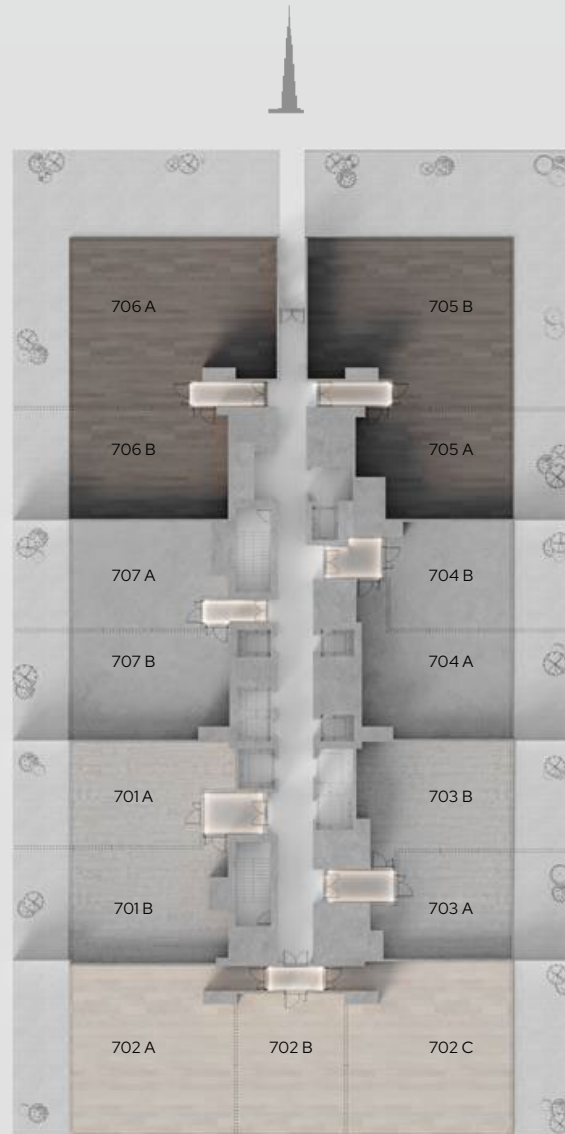
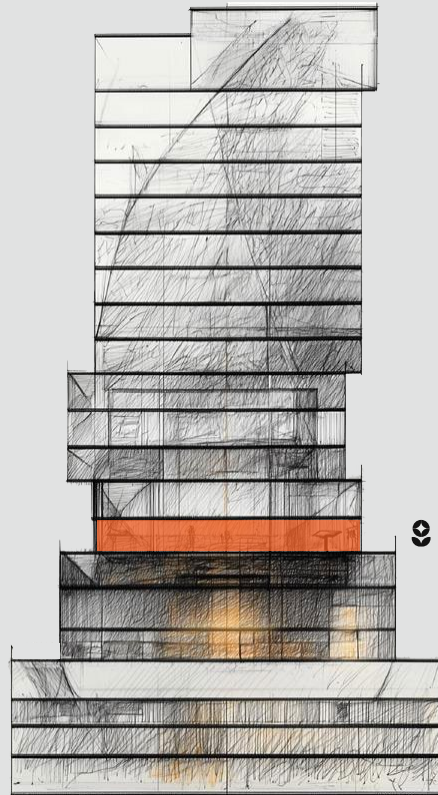

	INDOOR	OUTDOOR	TOTAL	PARKING	OCCUPANCY
CLUSTER 701	2186 FT ²	636 FT ²	2822 FT ²	4	19
701A	953 FT ²	315 FT ²	1268 FT ²	2	9
701B	1063 FT ²	321 FT ²	1384 FT ²	2	10
EXCLUSIVE LOBBY	170 FT ²				
CLUSTER 702	4359 FT ²	992 FT ²	5351 FT ²	10	41
702A	1698 FT ²	496 FT ²	2194 FT ²	4	16
702B	885 FT ²	-	885 FT ²	2	9
702C	1688 FT ²	496 FT ²	2184 FT ²	4	16
EXCLUSIVE LOBBY	88 FT ²				
CLUSTER 703	2003 FT ²	635 FT ²	2638 FT ²	4	18
703A	833 FT ²	321 FT ²	1154 FT ²	2	8
703B	1025 FT ²	314 FT ²	1339 FT ²	2	10
EXCLUSIVE LOBBY	145 FT ²				
CLUSTER 704	2018 FT ²	630 FT ²	2648 FT ²	4	18
704A	1076 FT ²	315 FT ²	1391 FT ²	2	10
704B	796 FT ²	315 FT ²	1111 FT ²	2	8
EXCLUSIVE LOBBY	146 FT ²				
CLUSTER 705	2991 FT ²	2056 FT ²	5047 FT ²	6	28
705A	956 FT ²	318 FT ²	1274 FT ²	2	9
705B	1916 FT ²	1738 FT ²	3654 FT ²	4	19
EXCLUSIVE LOBBY	119 FT ²				
CLUSTER 706	3104 FT ²	2069 FT ²	5173 FT ²	6	29
706A	1939 FT ²	1751 FT ²	3690 FT ²	4	19
706B	1043 FT ²	318 FT ²	1361 FT ²	2	10
EXCLUSIVE LOBBY	122 FT ²				
CLUSTER 707	2086 FT ²	630 FT ²	2716 FT ²	4	19
707A	932 FT ²	315 FT ²	1247 FT ²	2	9
707B	1045 FT ²	315 FT ²	1360 FT ²	2	10
EXCLUSIVE LOBBY	109 FT ²				



FLOOR 8

Classic Offices

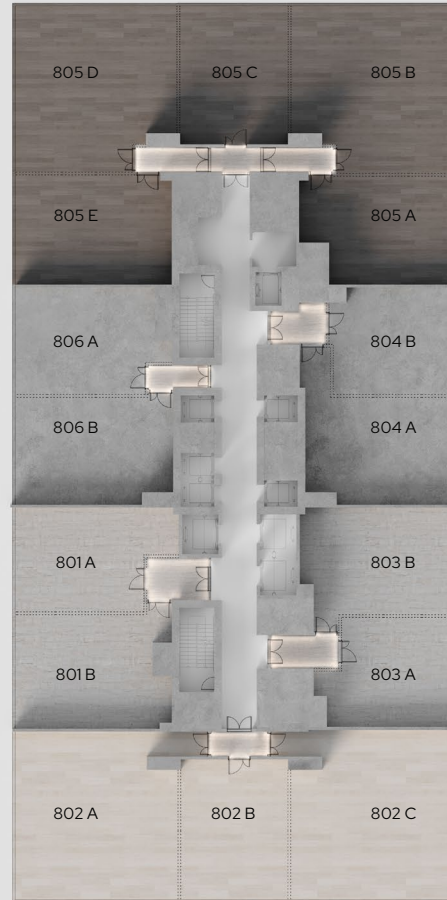
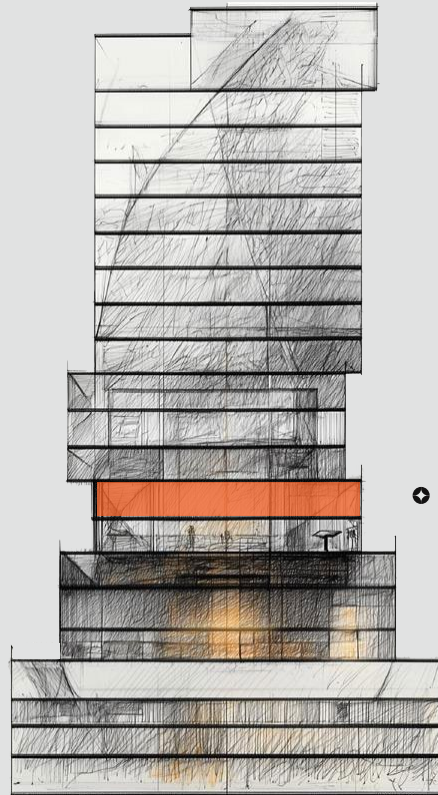

	INDOOR	PARKING	OCCUPANCY
CLUSTER 801	2186 FT ²	4	19
801A	953 FT ²	2	9
801B	1063 FT ²	2	10
EXCLUSIVE LOBBY	170 FT ²		
CLUSTER 802	4359 FT ²	8	41
802A	1698 FT ²	3	16
802B	885 FT ²	2	9
802C	1688 FT ²	3	16
EXCLUSIVE LOBBY	88 FT ²		
CLUSTER 803	2003 FT ²	3	18
803A	833 FT ²	1	8
803B	1025 FT ²	2	10
EXCLUSIVE LOBBY	145 FT ²		
CLUSTER 804	2018 FT ²	3	18
804A	1076 FT ²	2	10
804B	796 FT ²	1	8
EXCLUSIVE LOBBY	146 FT ²		
CLUSTER 805	6370 FT ²	12	58
805A	956 FT ²	2	9
805B	1577 FT ²	3	15
805C	904 FT ²	2	9
805D	1571 FT ²	3	15
805E	1043 FT ²	2	10
EXCLUSIVE LOBBY	319 FT ²		
CLUSTER 806	2086 FT ²	4	19
806A	932 FT ²	2	9
806B	1045 FT ²	2	10
EXCLUSIVE LOBBY	109 FT ²		



FLOOR 9

Terrace Offices

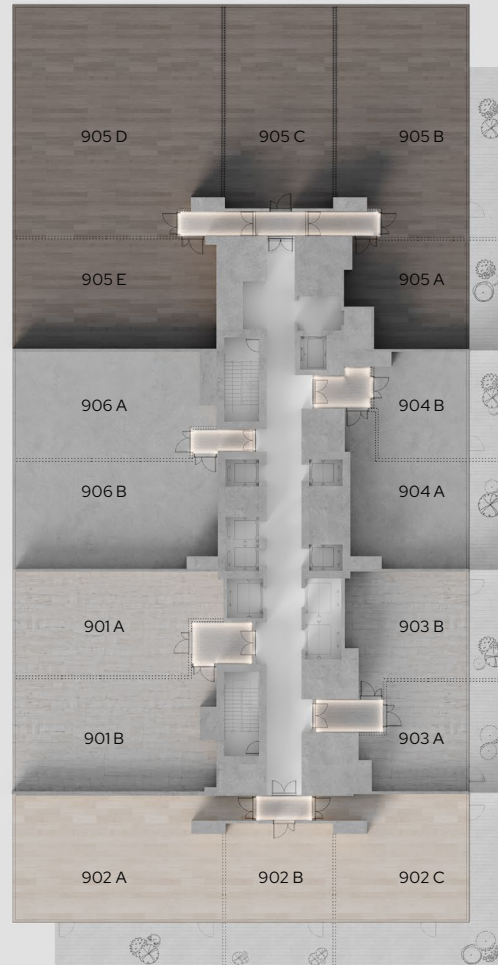
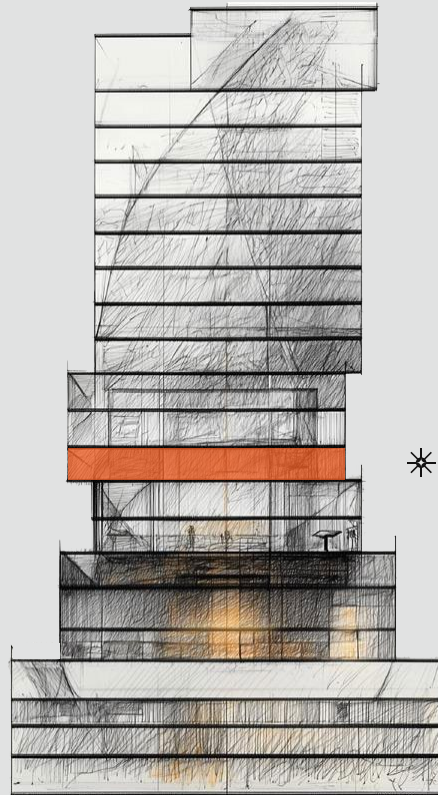

	INDOOR	OUTDOOR	TOTAL	PARKING	OCCUPANCY
CLUSTER 901	2719 FT ²	-	2719 FT ²	4	25
901A	1217 FT ²	-	1217 FT ²	2	12
901B	1332 FT ²	-	1332 FT ²	2	13
EXCLUSIVE LOBBY	170 FT ²				
CLUSTER 902	3334 FT ²	1336 FT ²	4670 FT ²	6	31
902A	1592 FT ²	417 FT ²	2009 FT ²	3	15
902B	619 FT ²	266 FT ²	885 FT ²	2	6
902C	1035 FT ²	653 FT ²	1688 FT ²	2	10
EXCLUSIVE LOBBY	88 FT ²				
CLUSTER 903	1598 FT ²	404 FT ²	2002 FT ²	4	14
903A	629 FT ²	204 FT ²	833 FT ²	2	6
903B	825 FT ²	200 FT ²	1025 FT ²	2	8
EXCLUSIVE LOBBY	144 FT ²				
CLUSTER 904	1618 FT ²	400 FT ²	2018 FT ²	4	14
904A	876 FT ²	200 FT ²	1076 FT ²	2	8
904B	596 FT ²	200 FT ²	796 FT ²	2	6
EXCLUSIVE LOBBY	146 FT ²				
CLUSTER 905	8079 FT ²	518 FT ²	8597 FT ²	15	76
905A	755 FT ²	201 FT ²	956 FT ²	2	7
905B	1723 FT ²	317 FT ²	2040 FT ²	4	17
905C	1271 FT ²	-	1271 FT ²	2	13
905D	2702 FT ²	-	2702 FT ²	5	26
905E	1309 FT ²	-	1309 FT ²	2	13
EXCLUSIVE LOBBY	319 FT ²				
CLUSTER 906	2613 FT ²	-	2613 FT ²	4	25
906A	1196 FT ²	-	1196 FT ²	2	12
906B	1309 FT ²	-	1309 FT ²	2	13
EXCLUSIVE LOBBY	108 FT ²				



FLOOR 10-II

Classic Offices

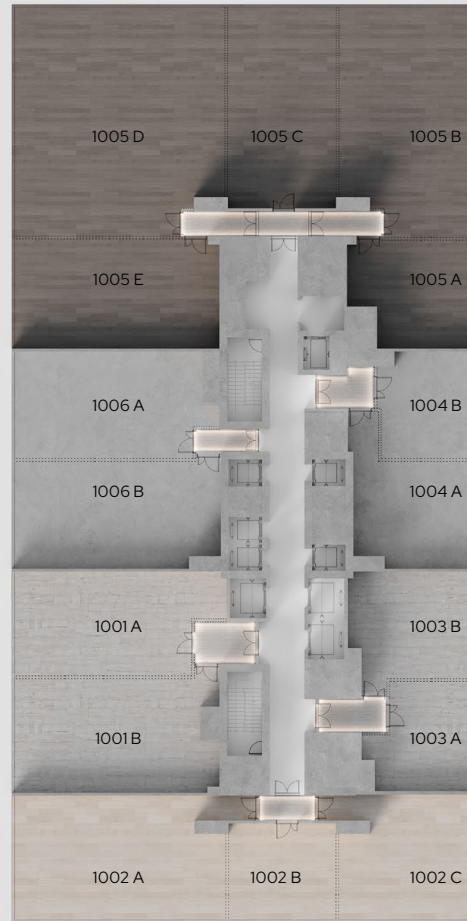
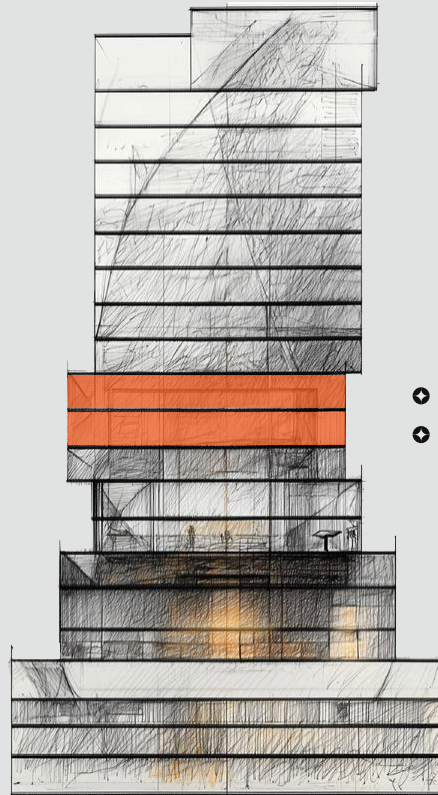

	INDOOR	PARKING	OCCUPANCY
CLUSTER 1001	2719 FT ²	4	25
1001A	1217 FT ²	2	12
1001B	1332 FT ²	2	13
EXCLUSIVE LOBBY	170 FT ²		
CLUSTER 1002	3334 FT ²	6	31
1002A	1592 FT ²	3	15
1002B	619 FT ²	1	6
1002C	1035 FT ²	2	10
EXCLUSIVE LOBBY	88 FT ²		
CLUSTER 1003	1598 FT ²	2	14
1003A	629 FT ²	1	6
1003B	825 FT ²	1	8
EXCLUSIVE LOBBY	144 FT ²		
CLUSTER 1004	1618 FT ²	3	14
1004A	876 FT ²	2	8
1004B	596 FT ²	1	6
EXCLUSIVE LOBBY	146 FT ²		
CLUSTER 1005	8079 FT ²	13	76
1005A	755 FT ²	1	7
1005B	1723 FT ²	3	17
1005C	1271 FT ²	2	13
1005D	2702 FT ²	5	26
1005E	1309 FT ²	2	13
EXCLUSIVE LOBBY	319 FT ²		
CLUSTER 1006	2613 FT ²	4	25
1006A	1196 FT ²	2	12
1006B	1309 FT ²	2	13
EXCLUSIVE LOBBY	108 FT ²		

FLOOR 12

Terrace Offices

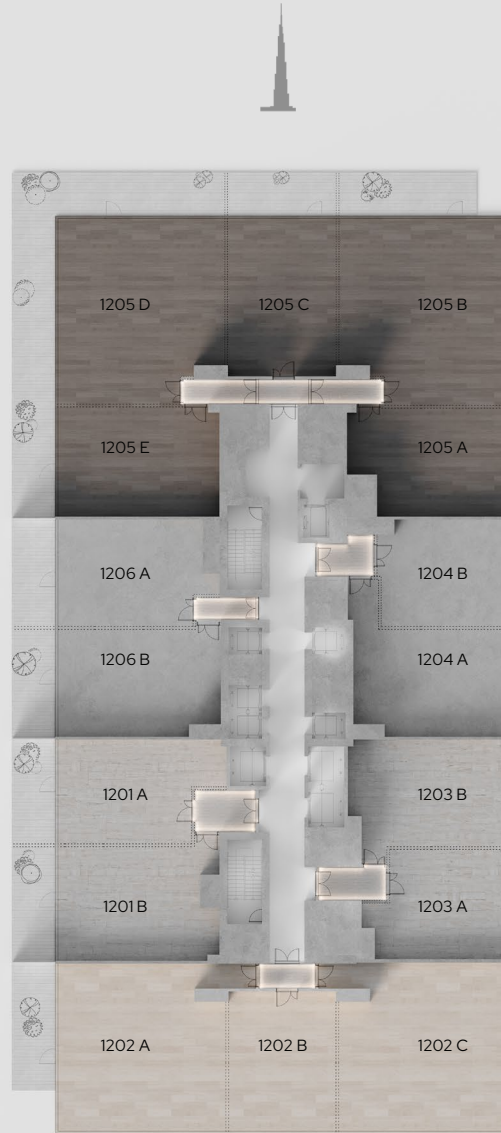
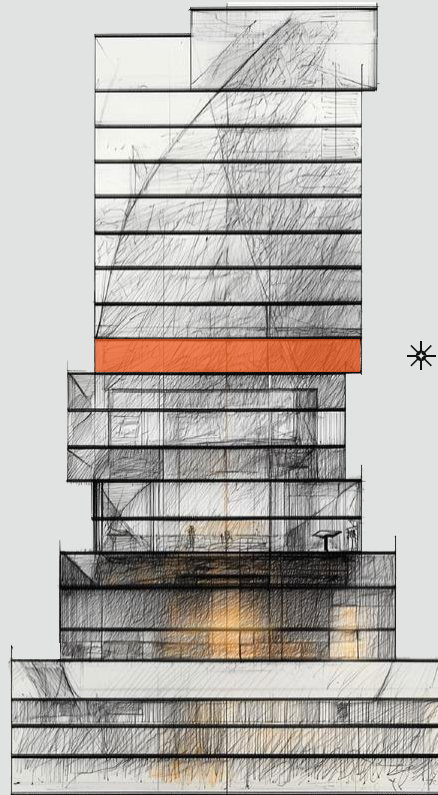

	INDOOR	OUTDOOR	TOTAL	PARKING	OCCUPANCY
CLUSTER 1201	2186 FT ²	533 FT ²	2719 FT ²	4	19
1201A	953 FT ²	264 FT ²	1217 FT ²	2	9
1201B	1063 FT ²	269 FT ²	1332 FT ²	2	10
EXCLUSIVE LOBBY	170 FT ²				
CLUSTER 1202	4359 FT ²	311 FT ²	4670 FT ²	9	41
1202A	1698 FT ²	311 FT ²	2009 FT ²	4	16
1202B	885 FT ²	-	885 FT ²	2	9
1202C	1688 FT ²	-	1688 FT ²	3	16
EXCLUSIVE LOBBY	88 FT ²				
CLUSTER 1203	2003 FT ²	-	2003 FT ²	3	18
1203A	833 FT ²	-	833 FT ²	1	8
1203B	1025 FT ²	-	1025 FT ²	2	10
EXCLUSIVE LOBBY	145 FT ²				
CLUSTER 1204	2018 FT ²	-	2018 FT ²	3	18
1204A	1076 FT ²	-	1076 FT ²	2	10
1204B	796 FT ²	-	796 FT ²	1	8
EXCLUSIVE LOBBY	146 FT ²				
CLUSTER 1205	6790 FT ²	1838 FT ²	8628 FT ²	14	63
1205A	956 FT ²	-	956 FT ²	2	9
1205B	1736 FT ²	334 FT ²	2070 FT ²	4	17
1205C	1006 FT ²	266 FT ²	1272 FT ²	2	10
1205D	1730 FT ²	972 FT ²	2702 FT ²	4	17
1205E	1043 FT ²	266 FT ²	1309 FT ²	2	10
EXCLUSIVE LOBBY	319 FT ²				
CLUSTER 1206	2086 FT ²	527 FT ²	2613 FT ²	4	19
1206A	932 FT ²	263 FT ²	1195 FT ²	2	9
1206B	1045 FT ²	264 FT ²	1309 FT ²	2	10
EXCLUSIVE LOBBY	109 FT ²				



FLOOR 13

Classic Offices

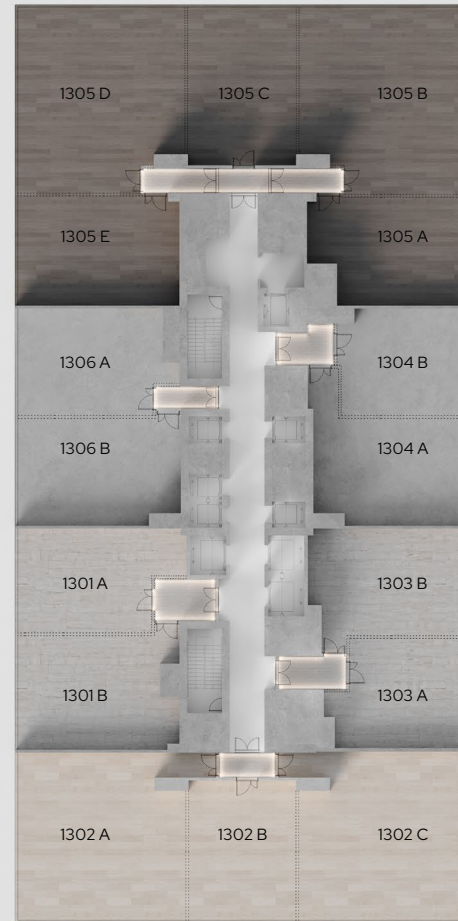
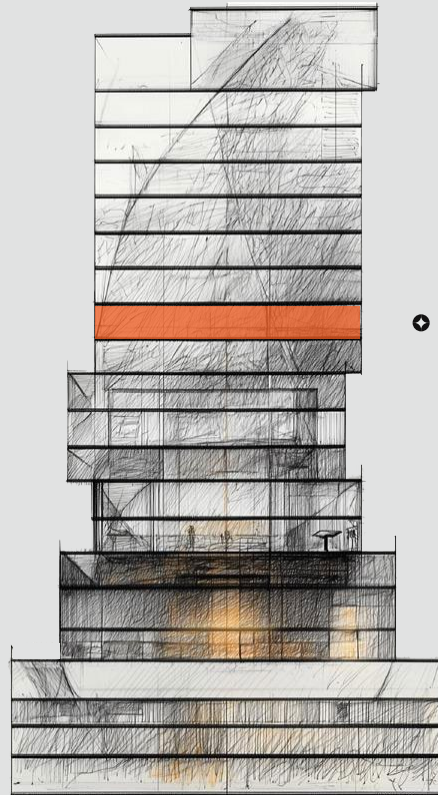

	INDOOR	PARKING	OCCUPANCY
CLUSTER I301	2186 FT ²	4	19
I301A	953 FT ²	2	9
I301B	1063 FT ²	2	10
EXCLUSIVE LOBBY	170 FT ²		
CLUSTER I302	4359 FT ²	8	41
I302A	1698 FT ²	3	16
I302B	885 FT ²	2	9
I302C	1688 FT ²	3	16
EXCLUSIVE LOBBY	88 FT ²		
CLUSTER I303	2003 FT ²	3	18
I303A	833 FT ²	1	8
I303B	1025 FT ²	2	10
EXCLUSIVE LOBBY	145 FT ²		
CLUSTER I304	2018 FT ²	3	18
I304A	1076 FT ²	2	10
I304B	796 FT ²	1	8
EXCLUSIVE LOBBY	146 FT ²		
CLUSTER I305	6790 FT ²	12	63
I305A	956 FT ²	2	9
I305B	1736 FT ²	3	17
I305C	1006 FT ²	2	10
I305D	1730 FT ²	3	17
I305E	1043 FT ²	2	10
EXCLUSIVE LOBBY	319 FT ²		
CLUSTER I306	2086 FT ²	2	19
I306A	932 FT ²	2	9
I306B	1045 FT ²	2	10
EXCLUSIVE LOBBY	109 FT ²		

FLOOR 14-16

Classic Offices

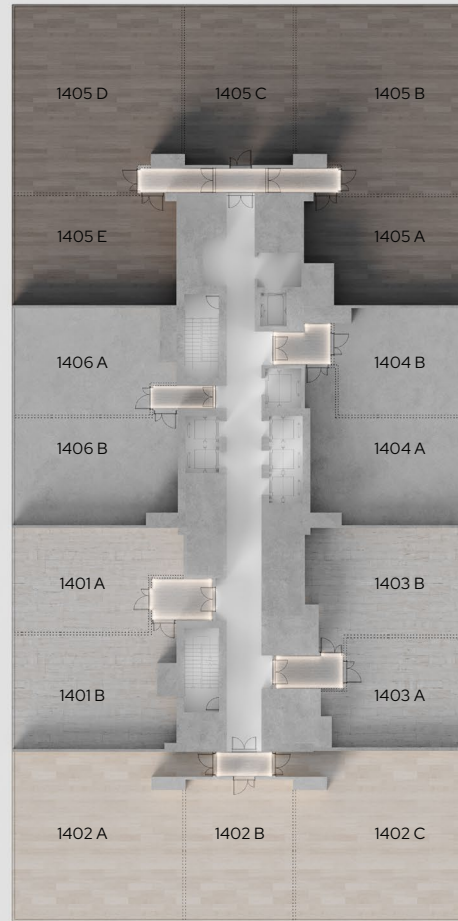
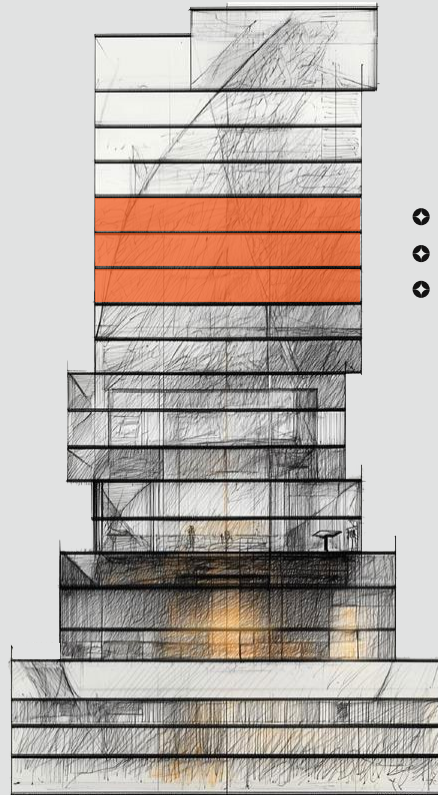

	INDOOR	PARKING	OCCUPANCY
CLUSTER 1401	2186 FT ²	4	19
1401A	953 FT ²	2	9
1401B	1063 FT ²	2	10
EXCLUSIVE LOBBY	170 FT ²		
CLUSTER 1402	4359 FT ²	8	41
1402A	1698 FT ²	3	16
1402B	885 FT ²	2	9
1402C	1688 FT ²	3	16
EXCLUSIVE LOBBY	88 FT ²		
CLUSTER 1403	2003 FT ²	3	18
1403A	833 FT ²	1	8
1403B	1025 FT ²	2	10
EXCLUSIVE LOBBY	145 FT ²		
CLUSTER 1404	2018 FT ²	3	18
1404A	1076 FT ²	2	10
1404B	796 FT ²	1	8
EXCLUSIVE LOBBY	146 FT ²		
CLUSTER 1405	6790 FT ²	12	63
1405A	956 FT ²	2	9
1405B	1736 FT ²	3	17
1405C	1006 FT ²	2	10
1405D	1730 FT ²	3	17
1405E	1043 FT ²	2	10
EXCLUSIVE LOBBY	319 FT ²		
CLUSTER 1406	2086 FT ²	4	19
1406A	932 FT ²	2	9
1406B	1045 FT ²	2	10
EXCLUSIVE LOBBY	109 FT ²		

FLOOR 17

Classic Offices

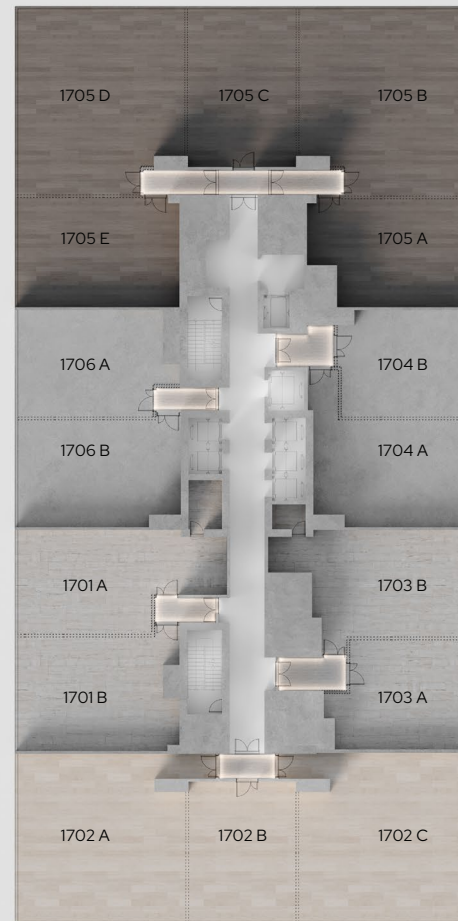
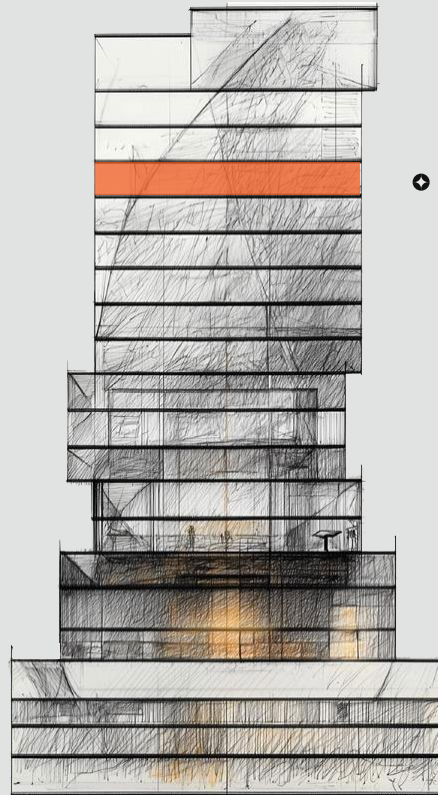

	INDOOR	PARKING	OCCUPANCY
CLUSTER 1701	2433 FT ²	4	22
1701A	1268 FT ²	2	12
1701B	1063 FT ²	2	10
EXCLUSIVE LOBBY	102 FT ²		
CLUSTER 1702	4359 FT ²	8	41
1702A	1698 FT ²	3	16
1702B	885 FT ²	2	9
1702C	1688 FT ²	3	16
EXCLUSIVE LOBBY	88 FT ²		
CLUSTER 1703	2169 FT ²	3	19
1703A	833 FT ²	1	8
1703B	1191 FT ²	2	11
EXCLUSIVE LOBBY	145 FT ²		
CLUSTER 1704	2018 FT ²	3	18
1704A	1076 FT ²	2	10
1704B	796 FT ²	1	8
EXCLUSIVE LOBBY	146 FT ²		
CLUSTER 1705	6790 FT ²	12	63
1705A	956 FT ²	2	9
1705B	1736 FT ²	3	17
1705C	1006 FT ²	2	10
1705D	1730 FT ²	3	17
1705E	1043 FT ²	2	10
EXCLUSIVE LOBBY	319 FT ²		
CLUSTER 1706	2086 FT ²	4	19
1706A	932 FT ²	2	9
1706B	1045 FT ²	2	10
EXCLUSIVE LOBBY	109 FT ²		

FLOOR 18-19

Classic Offices

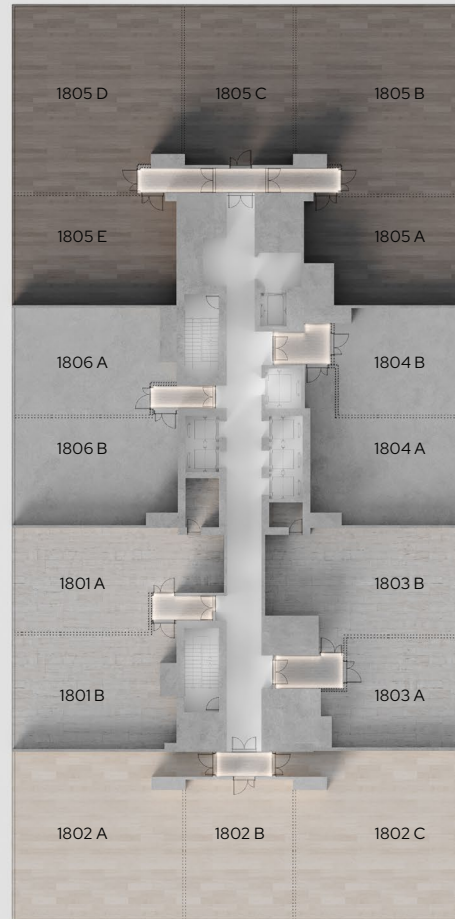
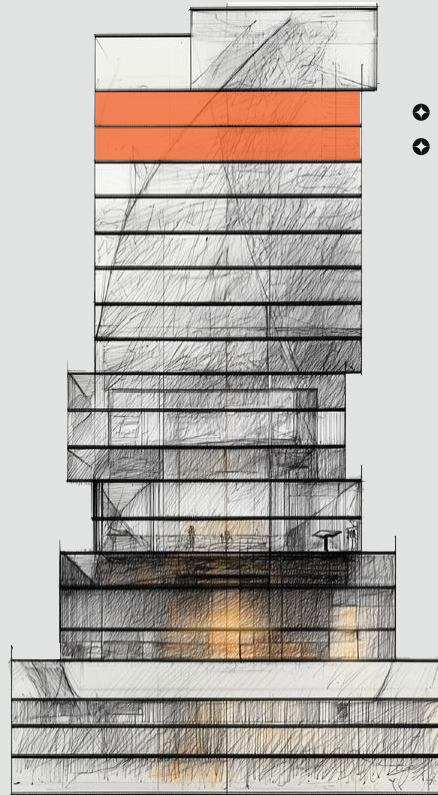

	INDOOR	PARKING	OCCUPANCY
CLUSTER 1801	2433 FT ²	4	22
1801A	1268 FT ²	2	12
1801B	1063 FT ²	2	10
EXCLUSIVE LOBBY	102 FT ²		
CLUSTER 1802	4359 FT ²	8	41
1802A	1698 FT ²	3	16
1802B	885 FT ²	2	9
1802C	1688 FT ²	3	16
EXCLUSIVE LOBBY	88 FT ²		
CLUSTER 1803	2279 FT ²	3	20
1803A	833 FT ²	1	8
1803B	1301 FT ²	2	12
EXCLUSIVE LOBBY	145 FT ²		
CLUSTER 1804	2018 FT ²	3	18
1804A	1076 FT ²	2	10
1804B	796 FT ²	1	8
EXCLUSIVE LOBBY	146 FT ²		
CLUSTER 1805	6790 FT ²	12	63
1805A	956 FT ²	2	9
1805B	1736 FT ²	3	17
1805C	1006 FT ²	2	10
1805D	1730 FT ²	3	17
1805E	1043 FT ²	2	10
EXCLUSIVE LOBBY	319 FT ²		
CLUSTER 1806	2086 FT ²	4	19
1806A	932 FT ²	2	9
1806B	1045 FT ²	2	10
EXCLUSIVE LOBBY	109 FT ²		

WORKSPACE CONFIGURATIONS

CLASSIC OFFICE

CLASSIC OFFICE 805D

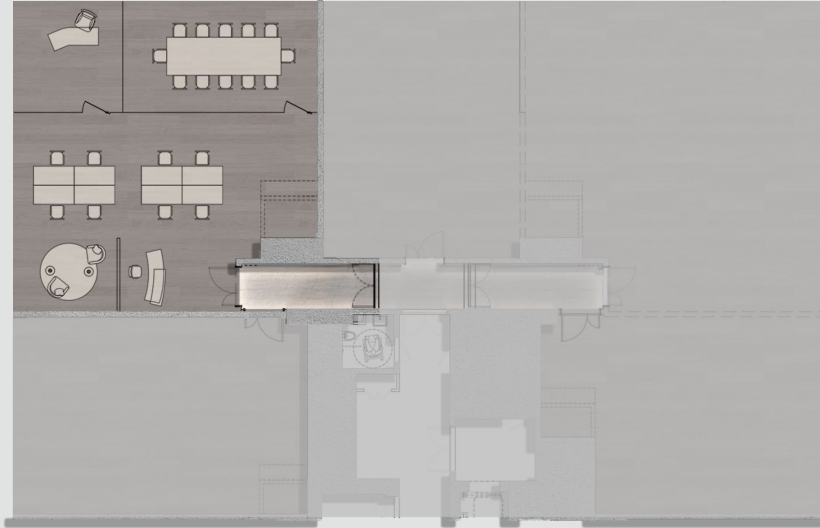

INTERNAL AREA: 1571 FT²
TOTAL AREA: 1571 FT²

LEVEL: 6, 8, 10-11, 13-19
DEDICATED PARKING: 3
OCCUPANCY: 15

CLASSIC OFFICE CLUSTER 805

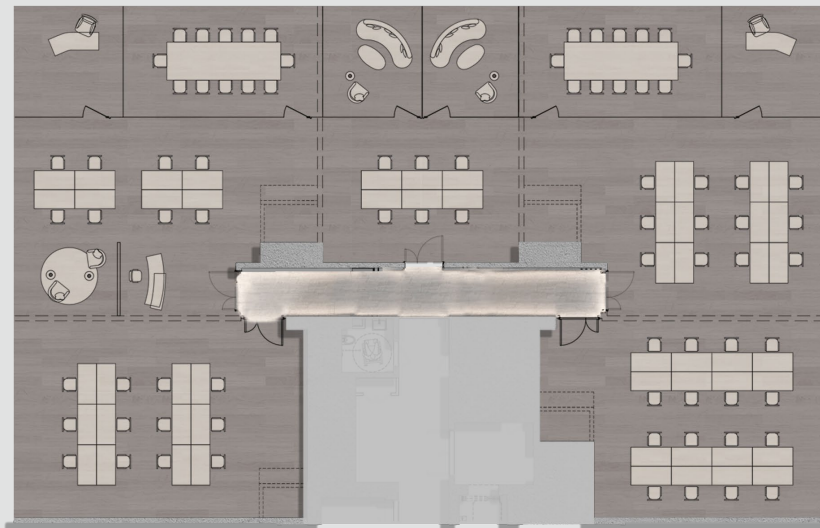

INTERNAL AREA: 6370 FT²
TOTAL AREA: 6370 FT²

LEVEL: 6, 8, 10-11, 13-19
DEDICATED PARKING: 12
OCCUPANCY: 58

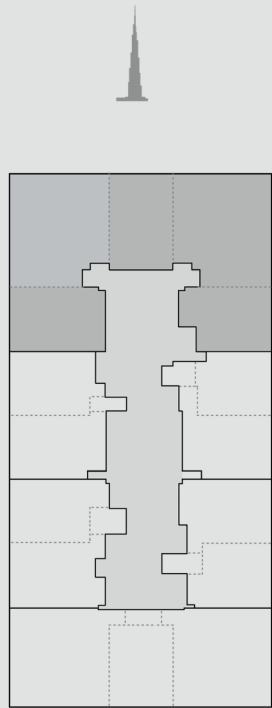

GARDEN OFFICE

GARDEN OFFICE 706A



INTERNAL AREA:	1939 FT ²
OUTDOOR AREA:	1751 FT ²
TOTAL AREA:	3690 FT ²
LEVEL:	7
DEDICATED PARKING:	4
OCCUPANCY:	19

GARDEN OFFICE CLUSTER 706

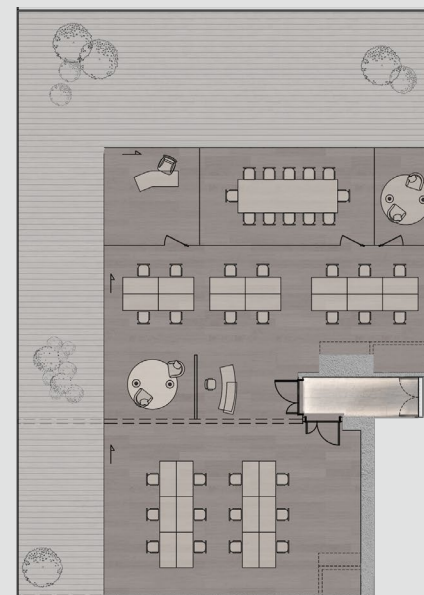

INTERNAL AREA:	3104 FT ²
OUTDOOR AREA:	2069 FT ²
TOTAL AREA:	5173 FT ²
LEVEL:	7
DEDICATED PARKING:	6
OCCUPANCY:	29

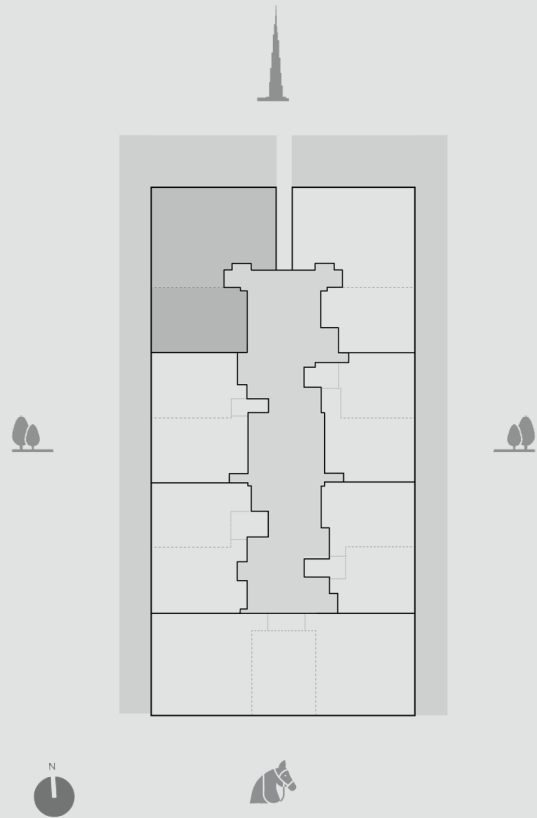

TERRACE OFFICE

TERRACE OFFICE 1205D



INTERNAL AREA:	1730 FT ²
OUTDOOR AREA:	972 FT ²
TOTAL AREA:	2702 FT ²
LEVEL:	9, 12
DEDICATED PARKING:	4
OCCUPANCY:	17

TERRACE OFFICE CLUSTER 1205

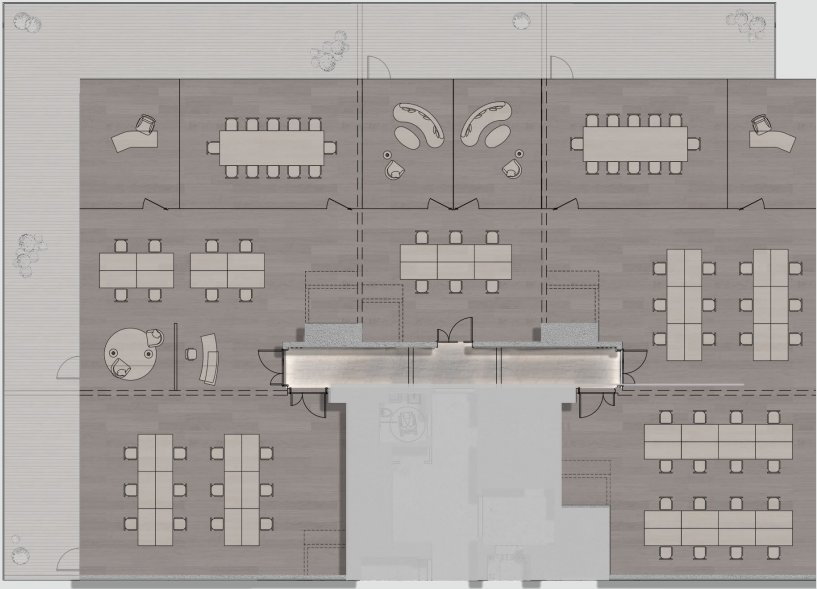

INTERNAL AREA:	6790 FT ²
OUTDOOR AREA:	1838 FT ²
TOTAL AREA:	8628 FT ²
LEVEL:	9, 12
DEDICATED PARKING:	14
OCCUPANCY:	63

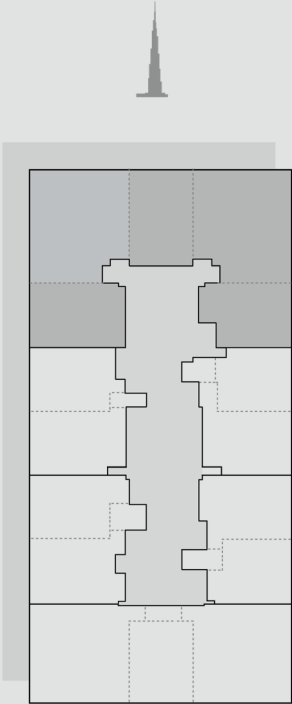

THE DEN

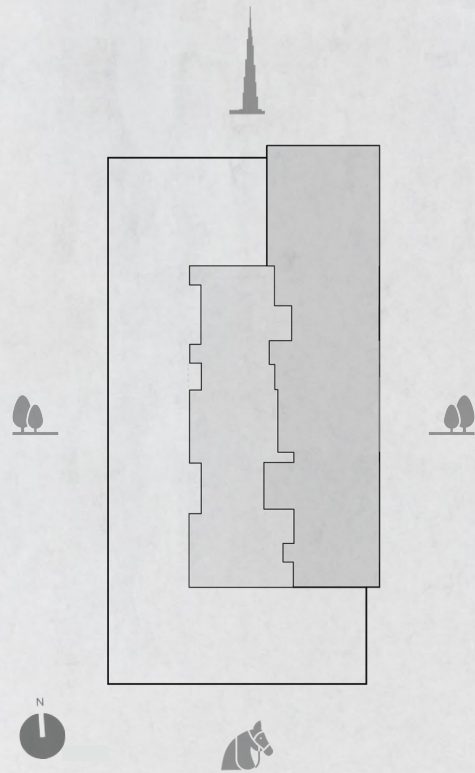

INTERNAL AREA:	10809 FT ²
OUTDOOR AREA:	11829 FT ²
SUMMER GARDEN AREA:	3869 FT ²
OUTDOOR PATIO AREA:	7,960 FT ²
TOTAL AREA:	22638 FT ²
LEVEL:	20
DEDICATED PARKING:	22 SPOTS
OCCUPANCY:	55

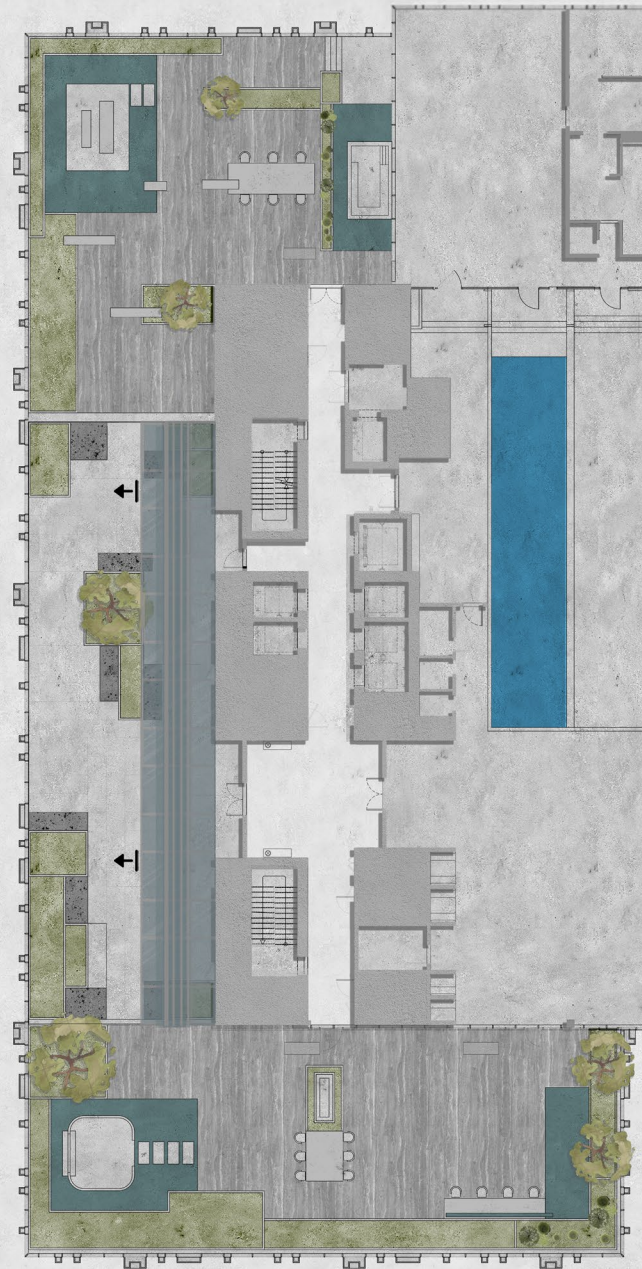

1 THE DEN

Penthouse of One

The one and the only penthouse office within Haus of Tenet, conceived as a private realm of leadership where clarity, control and distinction converge above the city.

2 INDOOR SWIMMING POOL

A Moment of Stillness

An indoor swimming pool reserved exclusively for The Den, designed for restoration and balance within a fully private setting.

3 SUMMER GARDEN

A Private Open-Air Retreat

A secluded garden with a retractable roof, offering light, air and calm.

ART AS OWNERSHIP CULTURE AS VALUE



MUSEUM OF TENET

AUTHENTIC

Authenticity is the origin story. Just as true art emerges from honesty, depth and intention, every space here is born from a genuine creative philosophy, crafted with meaning, shaped by culture and designed to feel unmistakably real.

EXCLUSIVE

Exclusivity isn't just rarity, it's owning something deeply personal. Like acquiring an original artwork, a space at Haus of Tenet offers a unique connection to artistry, design and cultural value reserved for those who truly appreciate it.

COLLECTIVE

Haus of Tenet redefines commercial real estate by positioning art as equity, not ornament. Curated, certified works are embedded into shared spaces, shaping environments of provenance and intent, where ownership extends beyond space to include narrative, identity and enduring cultural value.

THE COLLECTORS PROGRAM

OWN A SHARE OF A CURATED ART COLLECTION

Gain shared ownership in a professionally curated portfolio of mixed-media artworks placed throughout the development's public spaces.



STRENGTHENS YOUR INVESTMENT STORY

The integrated art program adds a unique dimension of cultural equity differentiating the project in the market and reinforcing smart, future-forward investing.

NO UPFRONT COST REQUIRED

The full initial investment in the art collection is covered by IRTH, allowing you to benefit without any additional financial contribution.

SPACES OF QUIET AUTHORITY



ACT I
FOR THE FEW

PRESTIGE
ARRIVAL

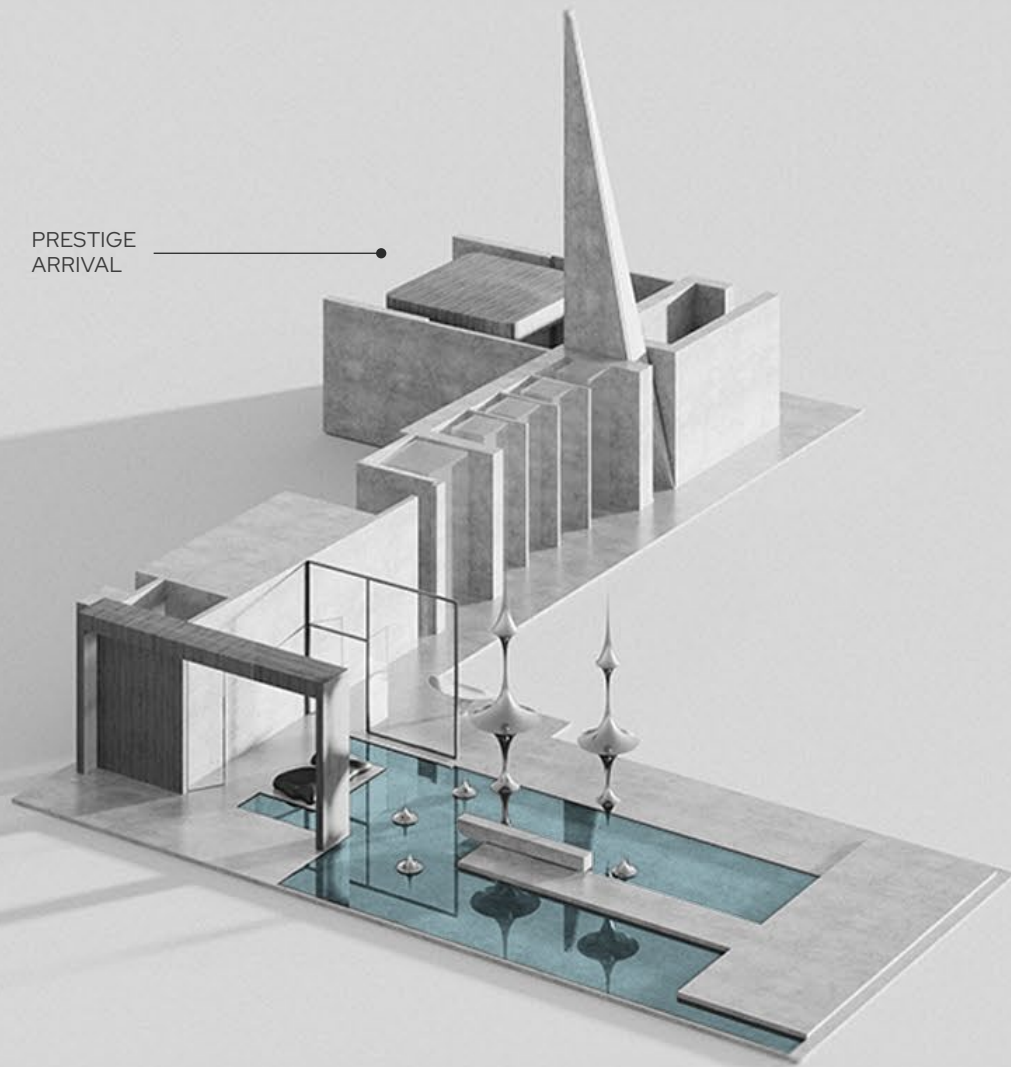

THE LOBBY EXPRESSION

Under this roof, power walks with grace and quality speaks softly.

Designed for those who value discretion and refinement. The lobby at Haus of Tenet is intimate, quiet and artfully curated. An exclusive sanctuary, an elegant transition space that feels as personal as a members-only lounge and as thoughtfully crafted as a collector's foyer.



PRESTIGE ARRIVAL

Private parking designed for discretion, ease and uninterrupted entry.

THE SWITCH

A discreet transition.

The Switch offers direct elevator and lobby access, ensuring privacy, control and a seamless arrival experience reserved for a select few.



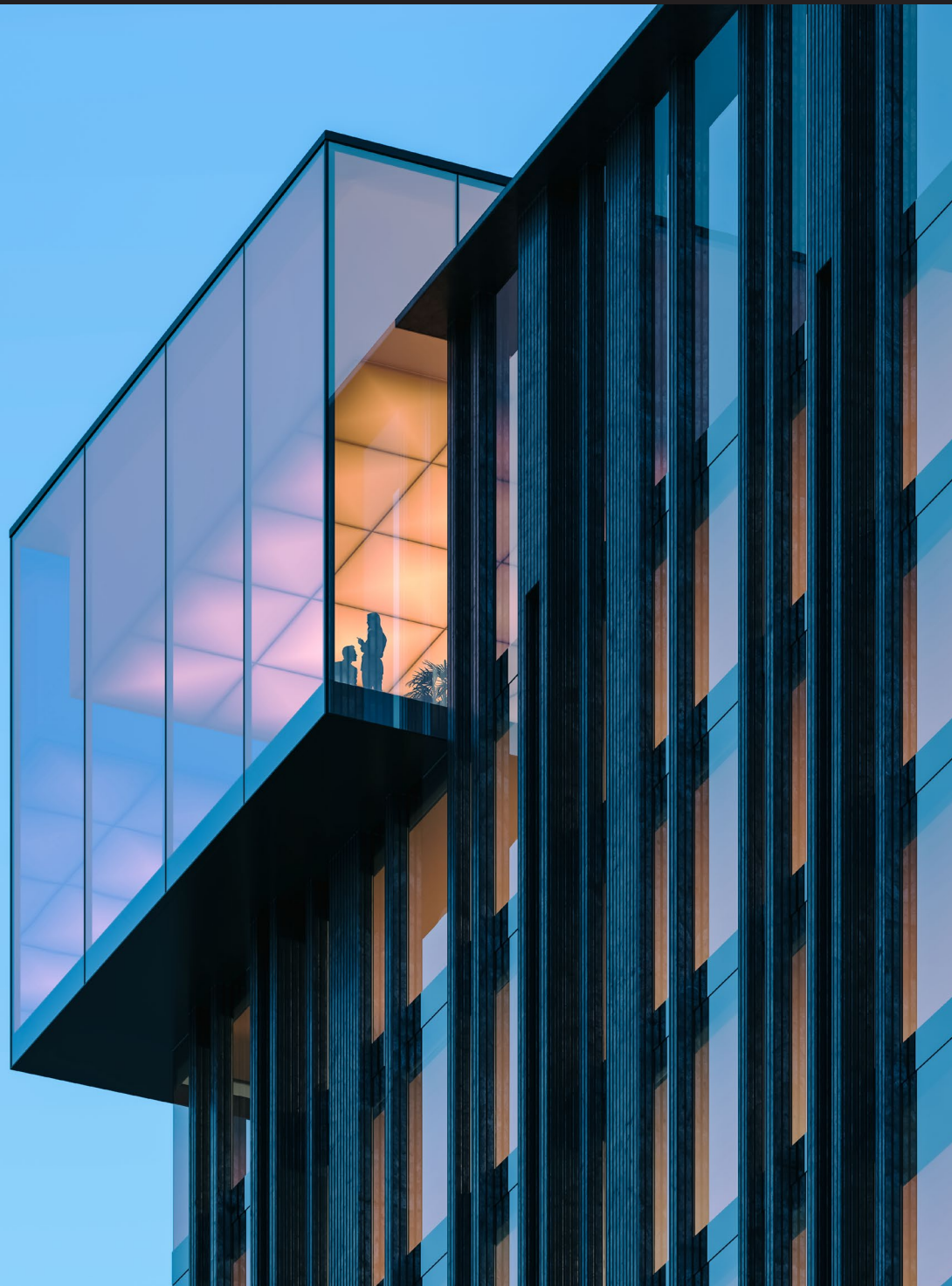

THE DEN

A full-floor workspace conceived as a private realm of clarity and distinction. Defined by expansive views, curated art and sculptural restraint, The Den offers an environment where presence is felt rather than declared.

More than an office, it is a place for those who lead with conviction, where decisions are shaped and legacy is authored at its highest level.

THE DEN

Penthouse of One

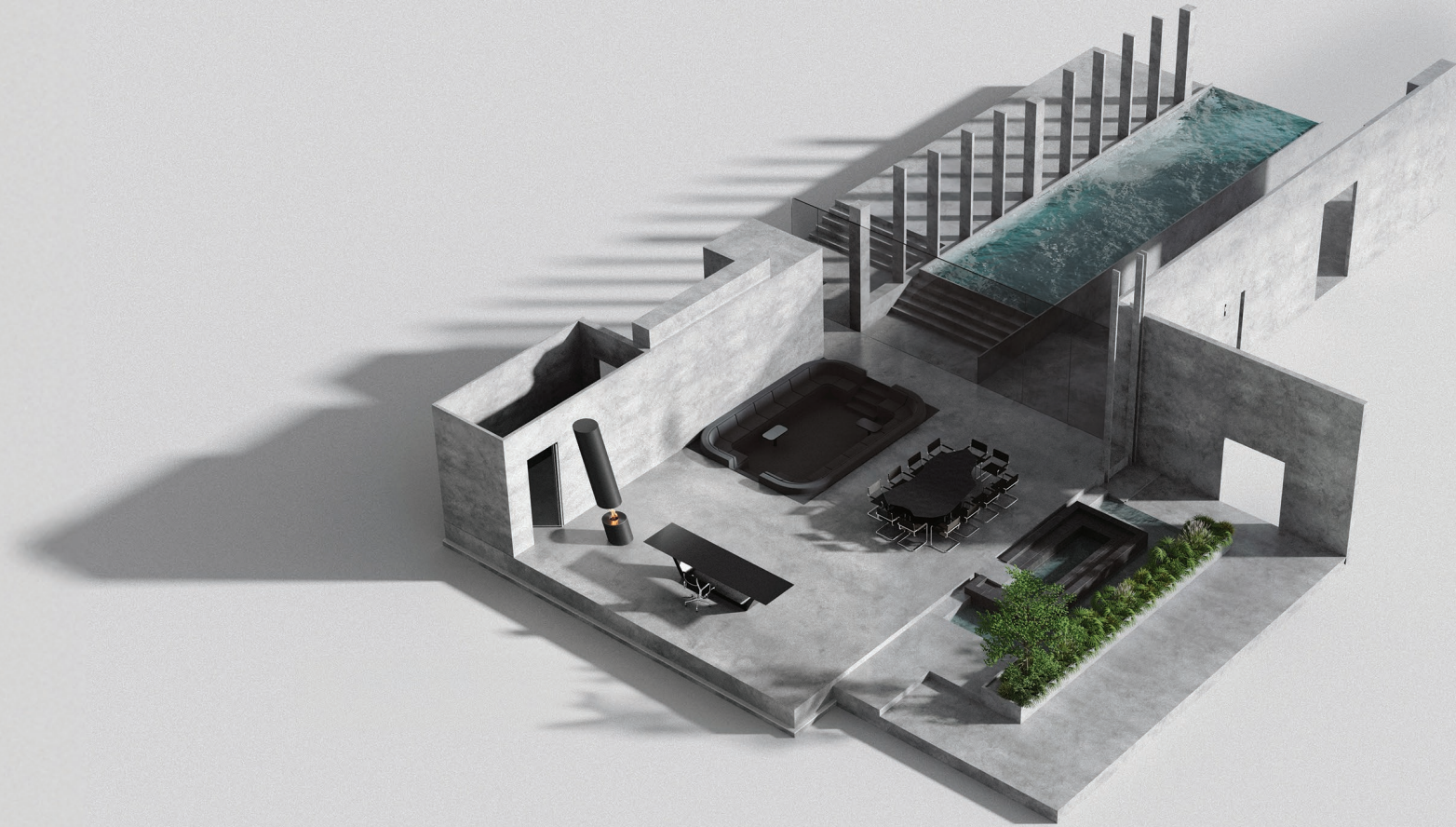



THE DEN

Private Outdoor Space

A secluded outdoor garden with a retractable roof, reserved exclusively for private use, offering light, air and calm.

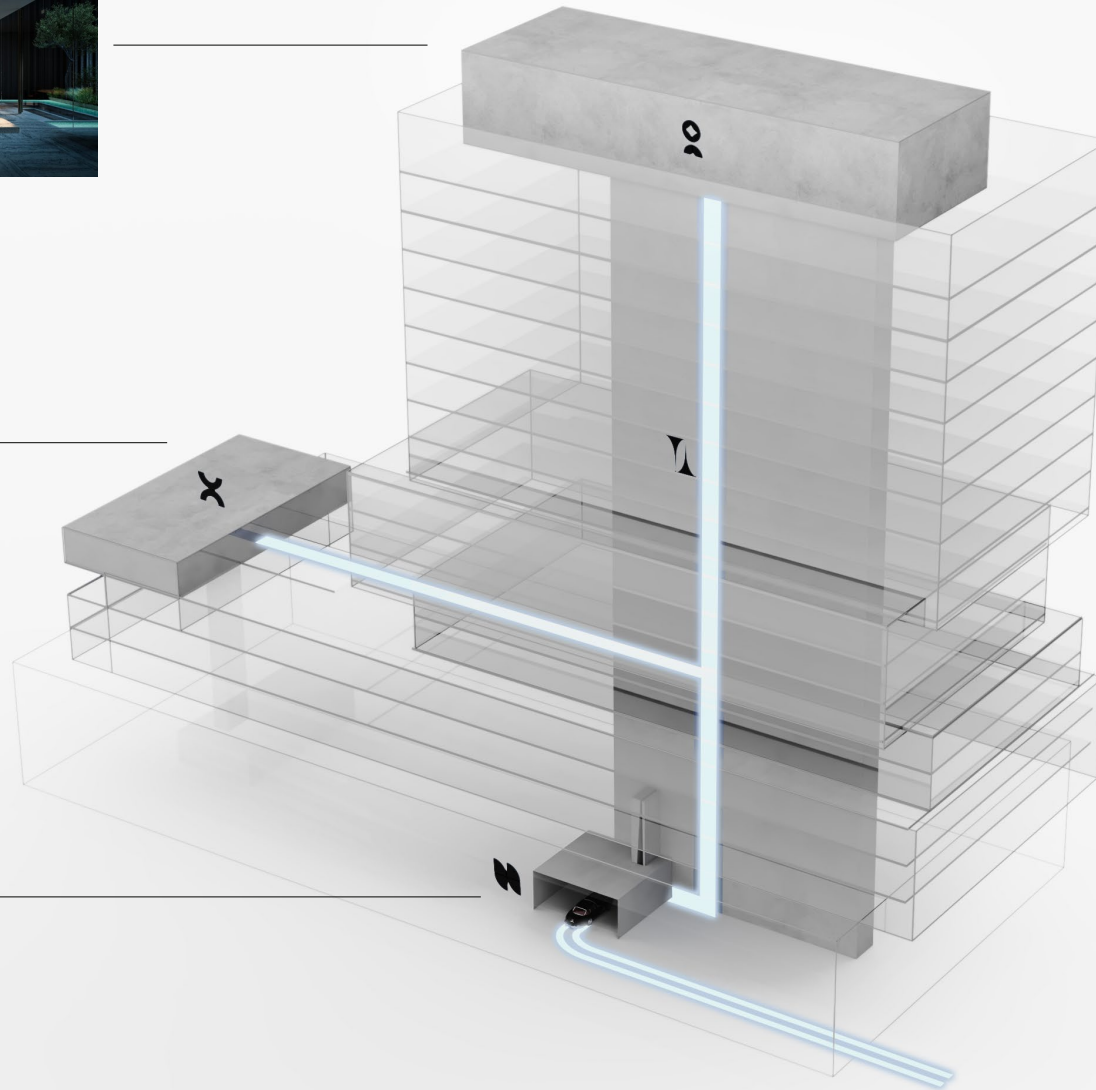
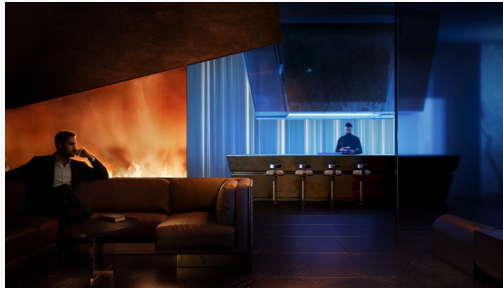

AN EXPERIENCE FOR THE FEW

Arrival at Haus of Tenet is composed, measured and deliberate. A moment of transition where pace slows, presence sharpens and control is instinctive.

Here, arrival is not announced, it is understood. An environment shaped for those who move with certainty, where discretion is assumed and refinement is felt, not stated.

This is the first signal of what lies beyond.

EXECUTIVE AMENITIES



DROP-OFF
PRESTIGE GUEST VALET

A dedicated drop-off point for the few
offering seamless valet service for a
signature guest experience



THE CORE

Wellness shaped by purpose and enduring balance.

INDULGENCE
CHAMBER



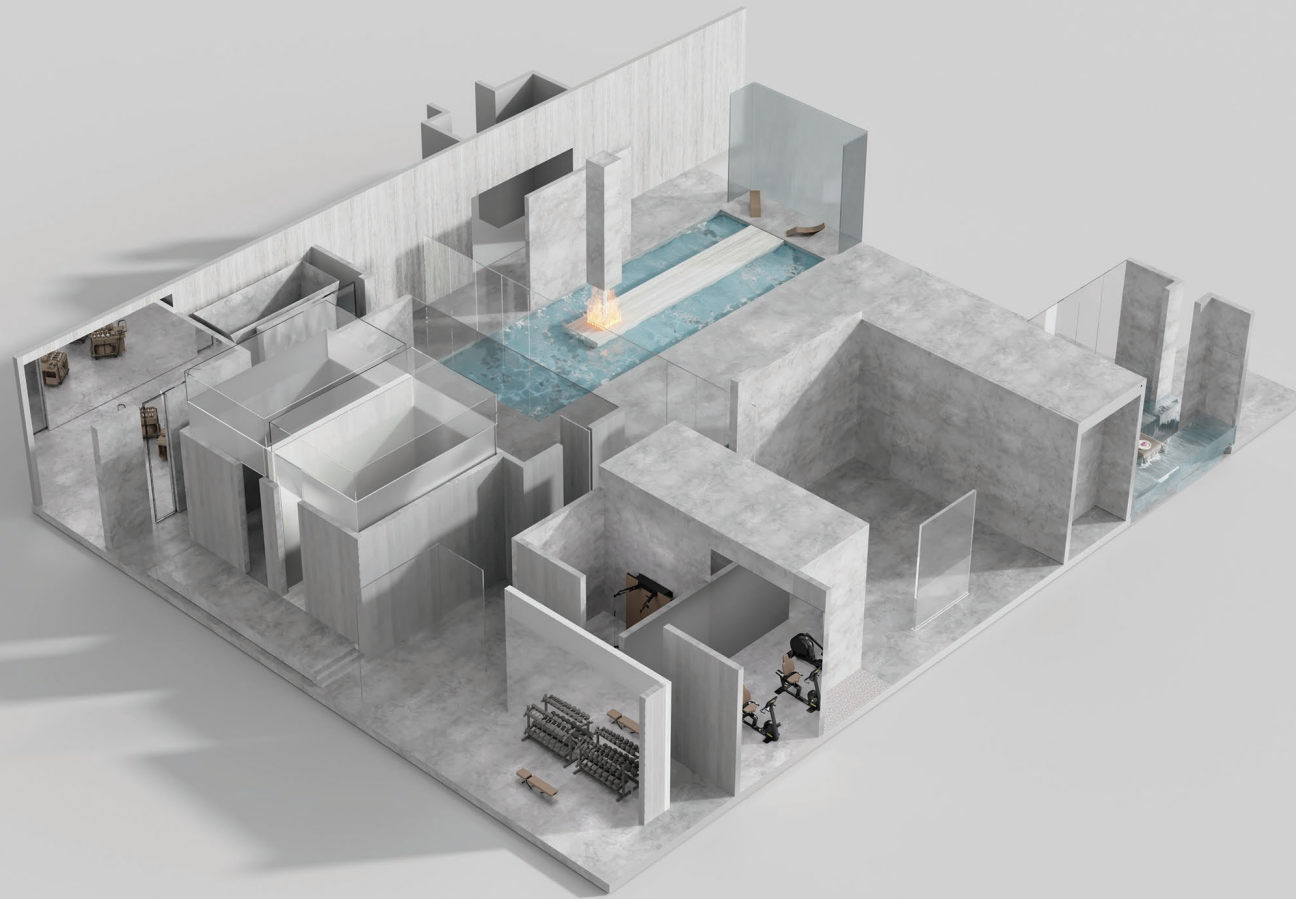

THE CORE

Elements

ELEMENT ONE | EARTH



ELEMENT TWO | AQUA



ELEMENT THREE | WIND



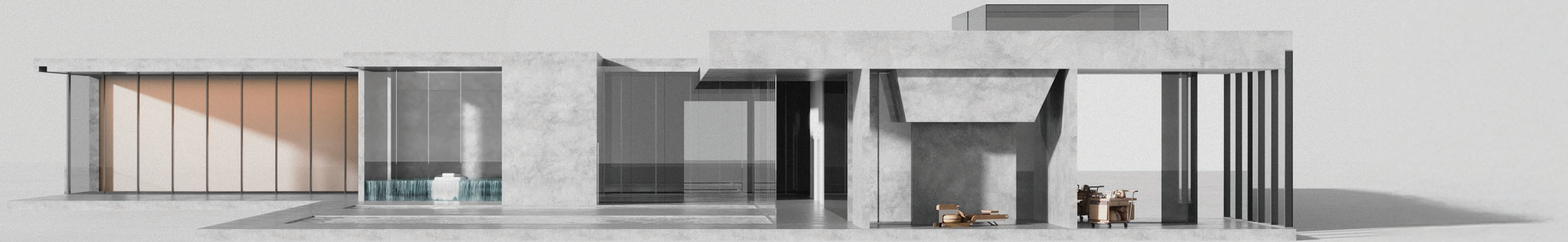

THE CORE

Crafted for exclusivity & designed for elevation

A man in a dark suit and white shirt is sitting on a brown leather sofa, looking thoughtfully to the right. The sofa is positioned in a lounge area. Behind him, a wall is illuminated with a bright orange and yellow fire effect. To the right, a bar area is visible with a bartender in a dark uniform standing behind the counter. The bar has four high stools with white seats. The floor is dark with a geometric pattern. The overall atmosphere is sophisticated and modern.

THE VAULT

Exclusive Signature Lounge,
defined by restraint & quiet authority.

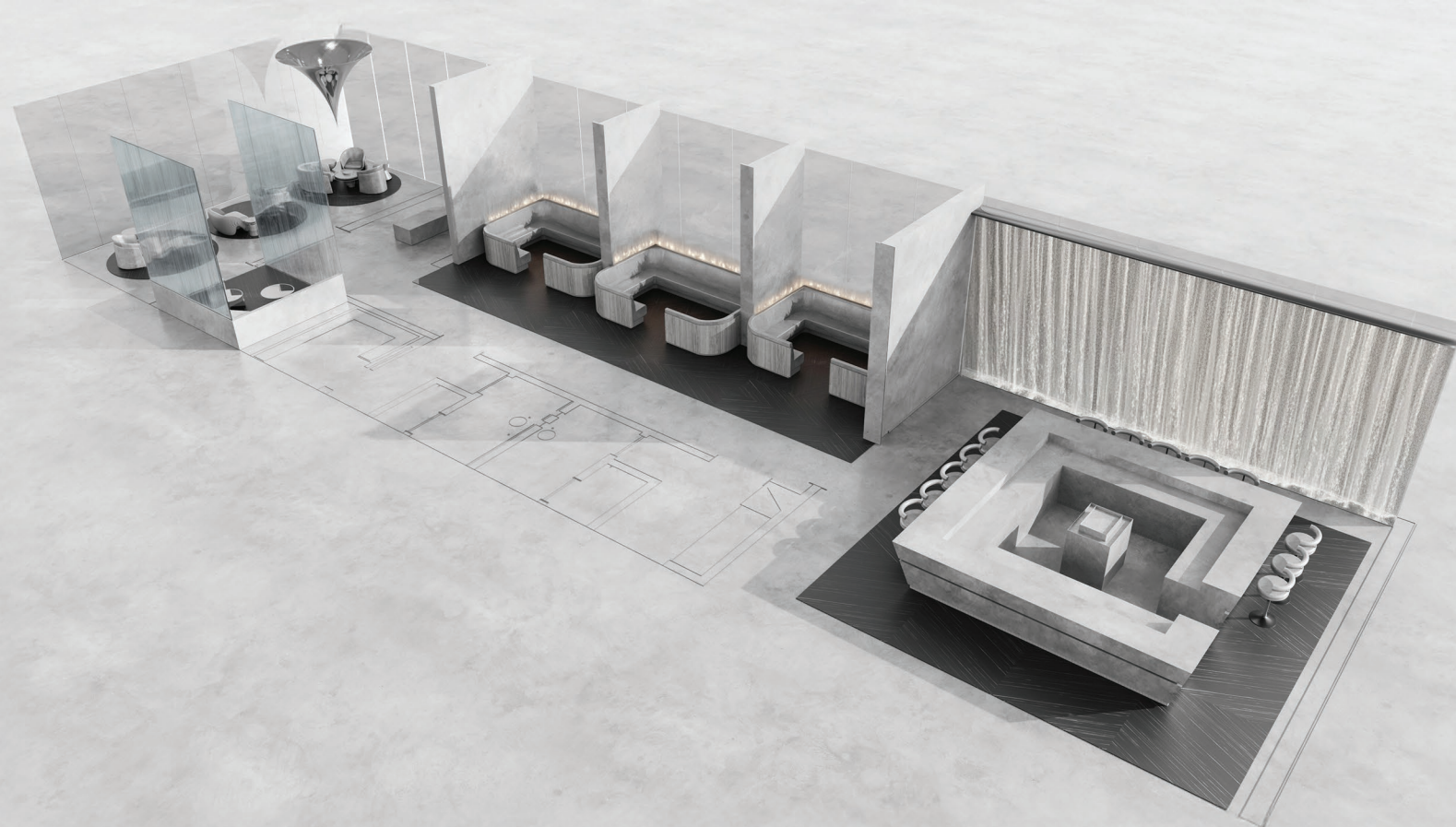

THE VAULT
The Elite Members Lounge

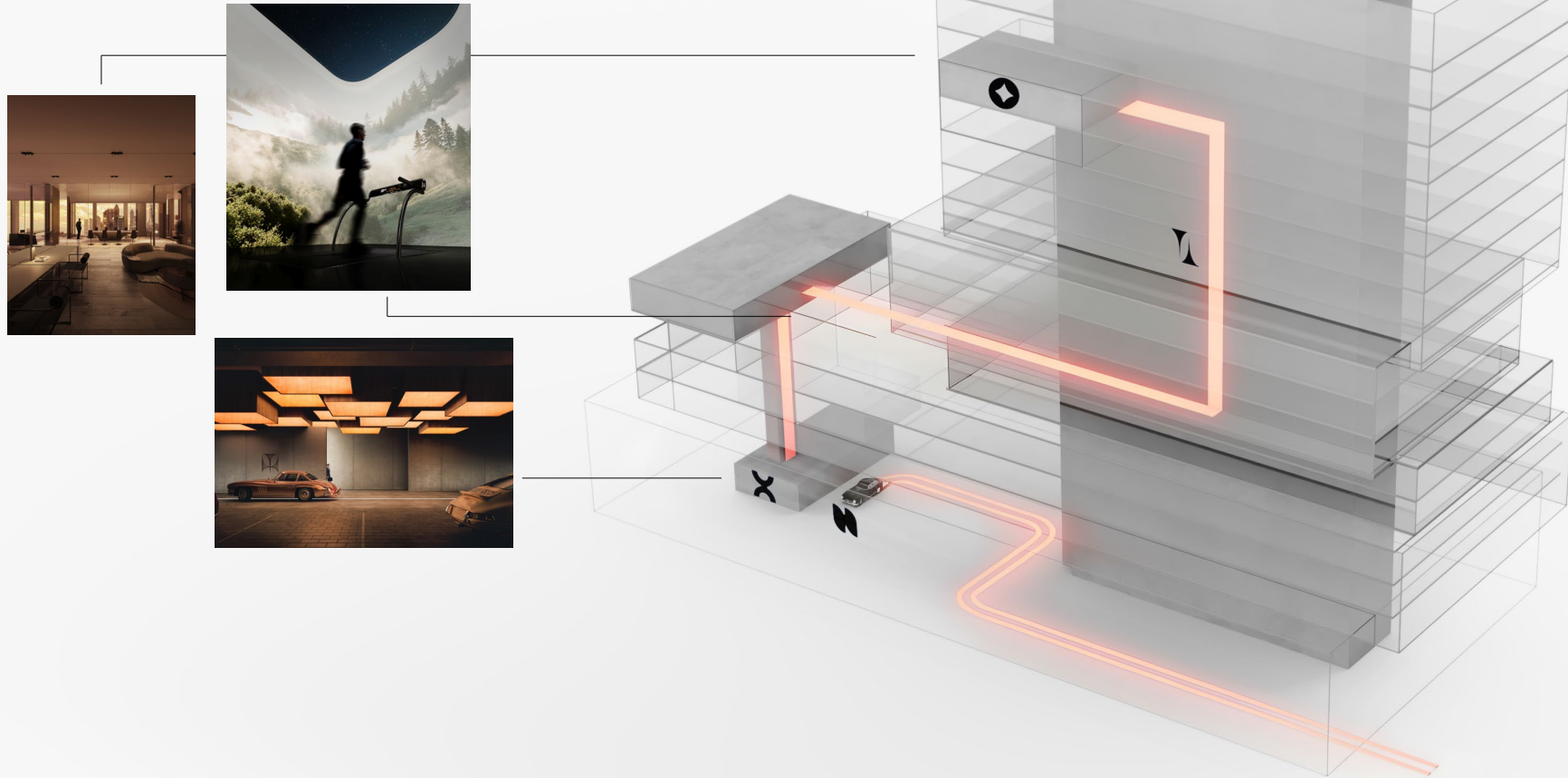

AMENITIES FOR THE FEW

A considered suite of amenities, shaped around the cadence of modern leadership.

Designed to restore balance, refine focus and elevate the everyday.

These spaces are an extension of The Den supporting those who operate at the highest level, with quiet consistency.

ACT 2
FOR THE MANY

A dark classic car, possibly a Jaguar, is parked in a modern, dimly lit interior space. The car is positioned in the lower center of the frame, facing right. To its left is a large, leafy tree in a dark, wide planter. The background consists of a wall of vertical, dark panels, possibly wood or metal, with some greenery visible through a recessed area. The floor is dark and reflective, showing a subtle reflection of the car. The overall atmosphere is sophisticated and minimalist.

WHERE ARRIVAL
BECOMES AUTHORITY



CRAFTED STILLNESS

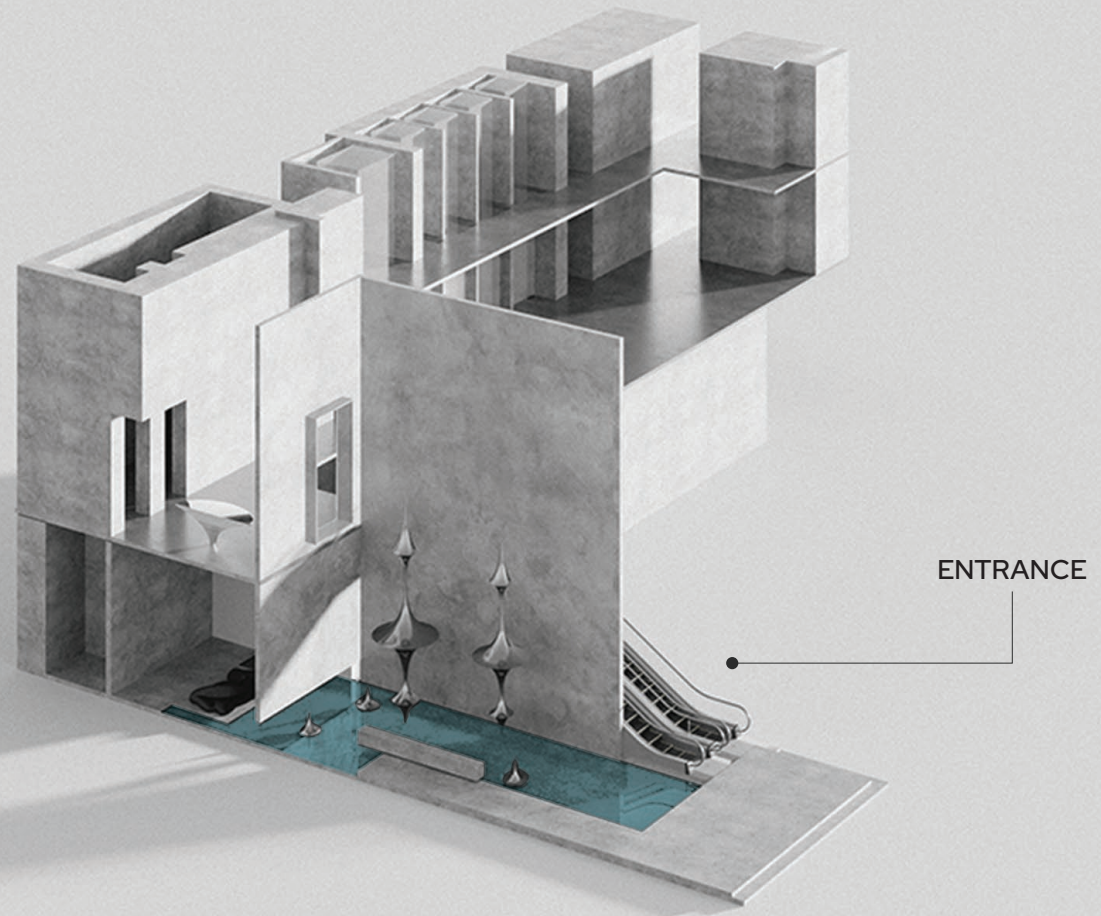

A movement through shadows, designed for those who embody rare presence.

THE ARRIVAL LOBBY

A Crafted Transition Space of Stillness and Welcome





THE FOUNDATION
Private Dining

THE BUNKER

A refined destination where dining, connection and quiet exclusivity meet



FOR THE MANY

Designed for those who lead with consistency, clarity and purpose. The shared spaces at Haus of Tenet are calm, composed and thoughtfully articulated environments that support focus, connection and daily rhythm.

Here, movement is effortless, spaces are intuitive and design serves function with quiet intelligence.

An experience shaped for those who carry responsibility with presence and progress with intent.

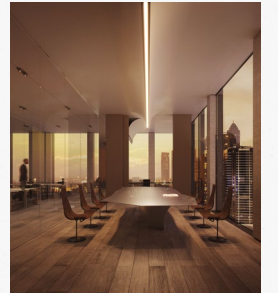
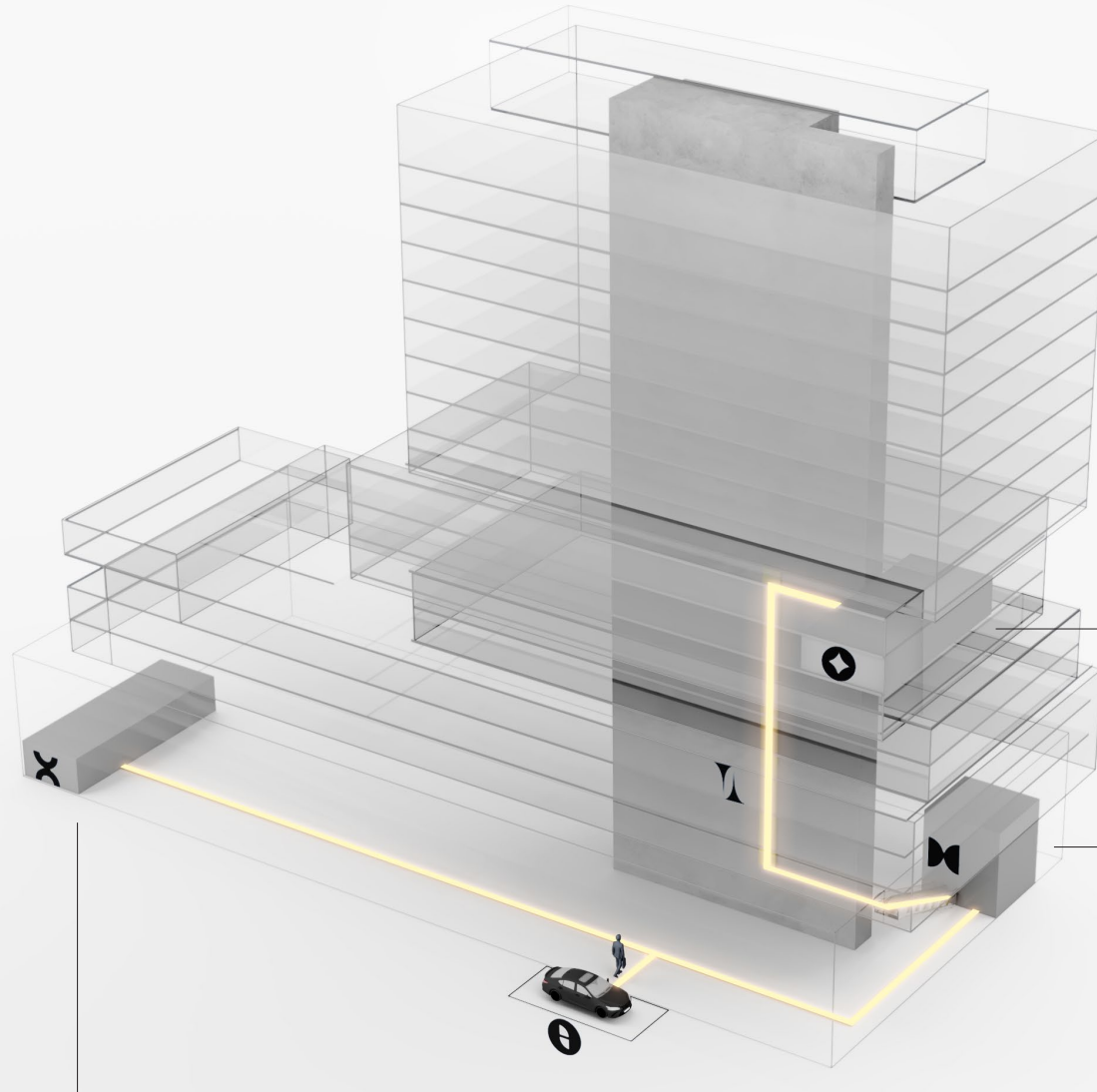

PROJECT DETAILS

PROJECT NAME
HAUS OF TENET

DEVELOPER
IRTH GROUP

GROSS FLOOR SIZE
324,107 FT²

TOTAL OFFICE FLOORS
15

TOTAL NUMBER OF OFFICES
87 CLUSTERS
UPTO 225 INDIVIDUAL OFFICE UNITS

TOTAL INDOOR & OUTDOOR
AMENITIES AREA
60,000 FT²

TOTAL PARKING BAYS
600 ACROSS 5 FLOORS

TOTAL NUMBER OF
ELEVATORS: 18
OFFICE | 12
EXCLUSIVE | 2
SHUTTLE | 3
SERVICE | 1

SERVICE CHARGES
≈ AED 20 PER SQFT

ANTICIPATED
HANDOVER DATE
Q2 2028

